

mitsubishi

三菱工業用ミシン部品カタログ

Industrial Sewing Machine Parts Catalog

Model PLK-E1010

目次	CONTENTS	Page
A 本体構成	Construction	1
B 本体関係 (1)	Arm bed & it's accessories (1).....	2
C 本体関係 (2)	Arm bed & it's accessories (2).....	4
D 縫い機構 (1)	Sewing mechanism (1).....	6
E 縫い機構 (2)	Sewing mechanism (2).....	8
F X-Yテーブル機構 (1)	X-Y table mechanism (1).....	10
G X-Yテーブル機構 (2)	X-Y table mechanism (2).....	12
H 外押え機構 (1)	Work holder mechanism (1).....	14
J 外押え機構 (2)	Work holder mechanism (2).....	16
K 糸切り機構	Thread trimming mechanism	18
L 中押え機構	Presser bar lifting mechanism	20
M ワイパー機構	Wiper mechanism	22
N 給油機構	Oil lubrication mechanism	24
P 配線検出器関係	Cable component & Detector mechanism	26
Q テーブル関係	Table & Stand	28
R 付属品 (1)	Accessories (1).....	30
S 付属品 (2)	Accessories (2).....	32
T オプションパーツ	Option parts	34
索引	Index	36

部品コードの採番形式

MITSUBISHI SPARE PARTS No. Designation system

1. 部品コードについて CONCERNING PARTS CODE.

部品をご注文される場合は、部品コードをお知らせください。

Please inform the part number, when these parts are ordered.

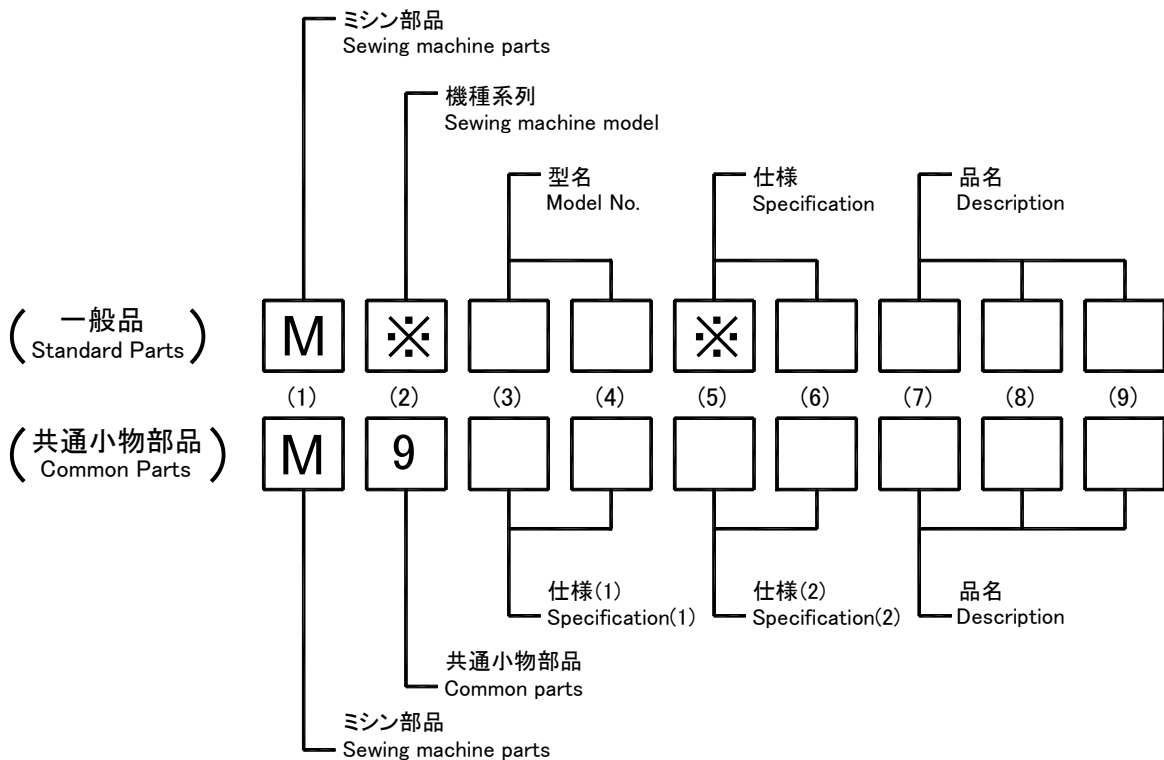

[例] Example

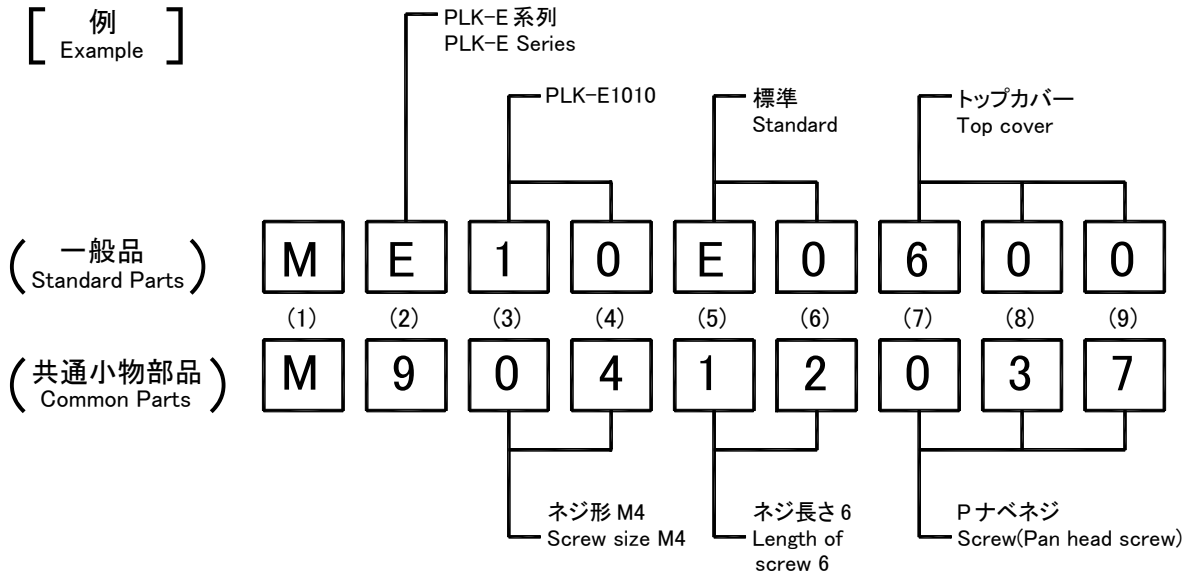

2. 変更マークについて CONCERNING MODIFICATION MARK.

変更マーク欄に*記号のある部品は、形状、寸法などの変更履歴がありますので、ご注文の際にはご使用の製品の製造番号と合わせてご覧ください。

The parts marked with * in the modification column has been changed the shape or size etc. So when these modified parts are ordered please inform the serial number of the sewing machine.

注: 一般品についての機種型名は、その部品が最初に使用された機種型名を示します。

従って長期にわたる場合は、機種の改廃が行われるため、当初の機種以外の機種で使用されている場合があります。

Sewing machine Models, of Standard Parts are Indicated model of these parts are registered firstly. Parts are used for not only the indicated model, but also another models, in reason of New development, improvement after.

B 本体関係(1)
 ARM BED & IT'S ACCESSORIES(1)

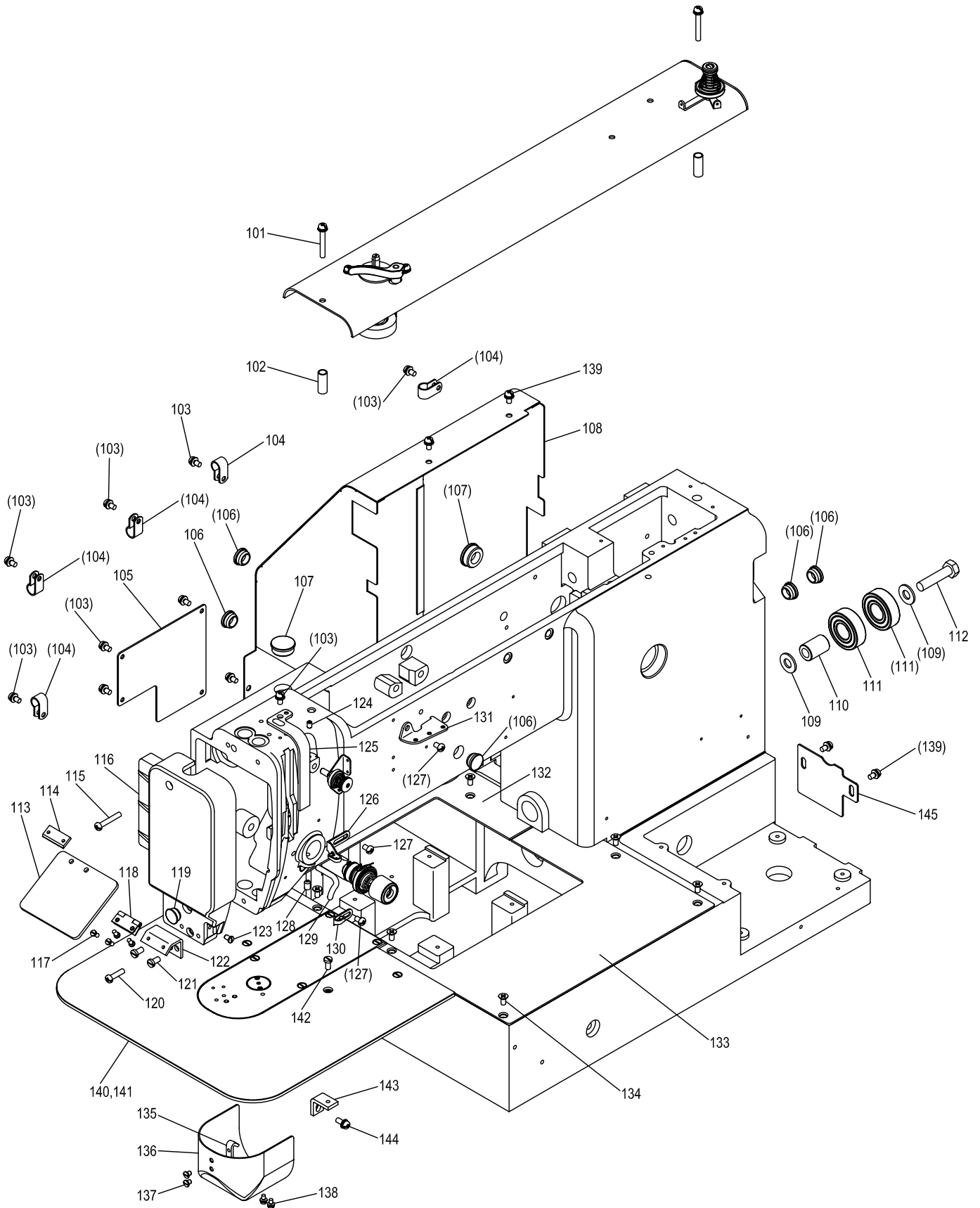

[B]本体関係(1)

ARM BED & IT'S ACCESSORIES (1)

Fig no.	変更 Mod.	部品コード Parts no.	品 名	Description	数量 Amt. Req.
B 101		M91276004	SW-PWプラスマイナネジ M4X30	Screw M4X30	2
B 102		MB62A0352	スペーサ 1382312-60200	Spacer	2
B 103		M91054004	SW-PWプラスマイナネジ M4X8	Screw M4X8	10
B 104		MN60A0620	ナイロンクリップ AB-5N	Nylon clip AB-5N	5
B 105		ME10A0742	フタ	Cover	1
B 106		M91304080	ゴムセン φ13	Rubber plug φ13	5
B 107		M91910080	ゴムセン φ19	Rubber plug φ19	2
B 108		ME10E0849	モータカバー	Motor cover	1
B 109		M90823050	ミガキサガネ 8	Washer 8	2
B 110		MB60A0750	ブッシュ	Bushing	1
B 111		MS10A1456	ジクウケ 6202ZZ	Bearing	2
B 112		M92057022	ロックアナツキホルト M8X35	Bolt M8X35	1
B 113		MS01A0160	アイガード	Eye guard	1
B 114		MS01A0477	ストッパ	Adapter	1
B 115		M90447037	プラスマイナネジ M4X25	Screw M4X25	1
B 116	B	ME10E1830	メンタ	Face cover	1
B 117		M90806002	ヒラネジ 1/8(44)X6	Screw 1/8(44)X6	4
B 118		MS01A1739	ヒンジ	Hinge	1
B 119		M91180080	ゴムセン φ11.8	Rubber plug φ11.8	1
B 120	B	M91014004	プラスマイナネジ M4X20	Screw M4X20	1
B 121		M91110002	ヒラネジ 11/64(40)X8	Screw 11/64(40)X8	2
B 122		MB60A0601	アイガードトリツケイタ	Eye guard bracket	1
B 123		M90908003	マルヒラネジ 9/64(40)X6	Screw 9/64(40)X6	1
B 124		M91053020	ロックアナツキメネジ M4X6	Screw M4X6	1
B 125		MA20A0584	テンピンカバー	Thread take-up lever guard	1
B 126		MG43A0181	イトアンナイ	Thread guide	1
B 127		M91011004	プラスマイナネジ M4X6	Screw M4X6	3
B 128		M95004020	ロックアナツキメネジ M5X8	Screw M5X8	1
B 129		MF70A1180	イトアンナイ	Thread guide	1
B 130		MF10A0181	イトアンナイ	Thread guide	1
B 131		MF36A1180	イトアンナイ	Thread guide	1
B 132		ME10A0339	X カバーイタ (L)	X Cover plate (L)	1
B 133		ME10A1339	X カバーイタ (R)	X Cover plate (R)	1
B 134		M91400010	Pサネジ M4X8	Screw M4X8	8
B 135		MS01A0361	カケガネ	Latch	1
B 136		MB60E6339	シリンダーカバー	Cylinder cover	1
B 137		M90906003	マルヒラネジ 9/64(40)X3.2	Screw 9/64(40)X3.2	2
B 138		M90859004	SW-PWプラスマイナネジ M3X6	Screw M3X6	2
B 139	B	M91071004	SW-MWプラスマイナネジ M4X8	Screw M4X8	6
B 140	B	ME10A1470	スベリイタ(外)	Slide plate (outside)	1
B 141	B	ME10A0797	ホコフィルム	Film sheet	1
B 142	B	M90990002	ヒラネジ M4X8	Screw M4X8	4
B 143	B	MB62A4601	トリツケイタ	Adapter	4
B 144	B	M91013004	SW-MWプラスマイナネジ M4X10	Screw M4X10	4
B 145	B	ME03A8339	カバー	Cover	1

From the library of: Diamond Needle Corp

C 本体関係(2)
ARM BED & IT'S ACCESSORIES(2)

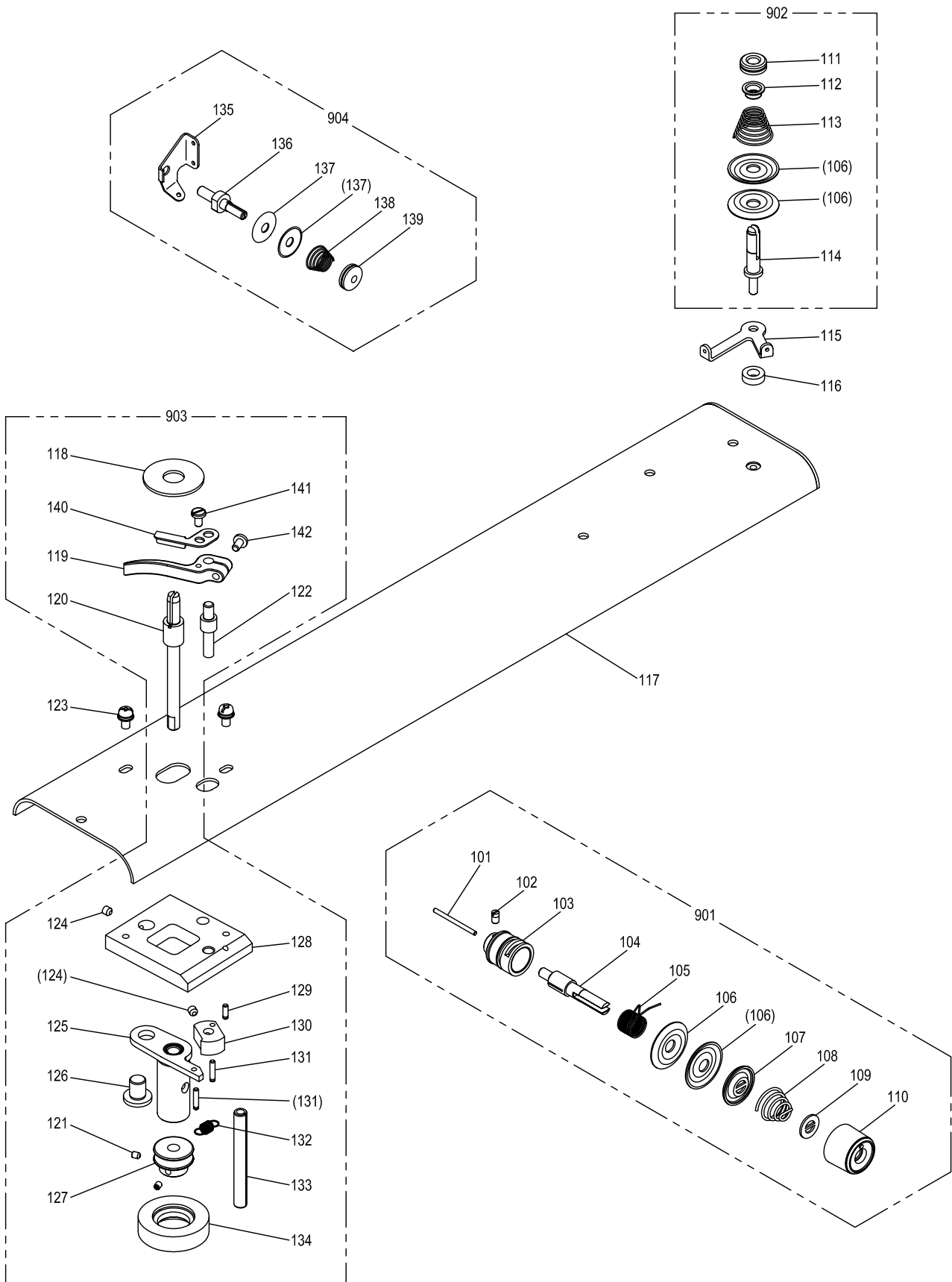

[C]本体関係(2)

ARM BED & IT'S ACCESSORIES(2)

Fig no.	変更 Mod.	部品コード Parts no.	部品名	Description	数量 Amt. Req.
C 101		M90204060	ピン	Pin	1
C 102		M90901002	ヒラネジ 9/64(40)X4	Screw 9/64(40)X4	1
C 103		MF10A0709	ブッシュ	Regulator casing	1
C 104		MF10A0553	チョウシホウ	Thread tension stud	1
C 105		MF10A0187	イトリハネ	Thread take-up spring	1
C 106		MF10A0555	チョウシサラ	Thread tension discs	4
C 107		MM11A0556	チョウシサラオサエ	Disc retaining plate	1
C 108		MN52A1245	エンスイハネ	Thread tension spring	1
C 109		MT60A0802	マワリトメ	Thumb nut revolution stopper	1
C 110		M91605045	ツマミナット	Thumb nut	1
C 111		M91602046	ツマミナット	Thumb nut	1
C 112		MM11A0702	ハネアンナイ	Spring guide	1
C 113		MM11A0245	エンスイハネ	Thread tension spring	1
C 114		MS14A0553	チョウシホウ	Thread tension stud	1
C 115		MS14A0180	イトアンナイ	Thread guide	1
C 116		MG75A1476	スペーサー	Spacer	1
C 117		ME10E0600	トップカバー	Top cover	1
C 118		MA20A0476	スペーサー	Spacer	1
C 119	B	ME25A0950	レバー	Lever	1
C 120		MA04A1530	ダンツキジク D	Driven shaft	1
C 121		M91057020	ロッククアナツキトメネジ M3X4	Screw M3X4	2
C 122		MA04A2530	ダンツキジク	Shaft	1
C 123	B	M91013004	SW-MWプラマイナヘネジ M4X10	Screw M4X10	2
C 124		M91055020	ロッククアナツキトメネジ M4X4	Screw M4X4	2
C 125		MB60E0950	レバークミタテ	Lever	1
C 126		M99006063	ピン	Pin	1
C 127		MA20A0194	イトマキグルマ	Wheel	1
C 128		MB60A1601	トリツケイタ	Bracket	1
C 129		M91004067	ミゾツキピン BXガタ φ 2.5X8	Pin φ 2.5X8	1
C 130		MS14A0350	カム	Cam	1
C 131		M91005067	ミゾツキピン BXガタ φ 2.5X12	Pin φ 2.5X12	2
C 132		MS14A0572	ツルマキハネ	Spring	1
C 133		M90601064	スプリングピン φ 6X56	Pin φ 6X56	1
C 134		MS03A0417	ゴムワ	Tire	1
C 135		MF00A0181	イトアンナイ	Thread guide	1
C 136		MF00A0553	チョウシホウ	Thread tension stud	1
C 137		MF10A1555	チョウシサラ	Thread tension discs	2
C 138		MF36A0245	エンスイハネ	Thread tension spring	1
C 139		M91101046	ツマミナット	Thumb nut	1
C 140	B	ME25A0551	チョウセツイタ	Adjuster plate	1
C 141	B	M90920002	ヒラネジ 9/64(40)X6.5	Screw 9/64(40)X6.5	1
C 142	B	M90939002	ヒラネジ 9/64(40)X11	Screw 9/64(40)X11	1
C 901		MA16E0210	チョウセツキミタテ	Thread tension Regulator assy	1
C 902		MS14E0180	チョウセツキミタテ	Thread tension Regulator assy	1
C 903		MB60E0190	イトマキソウチクミタテ	Bobbin winder	1
C 904		MF00E0550	チョウセツキミタテ	Thread tension Regulator assy	1

D 縫い機構(1)
SEWING MECHANISM(1)

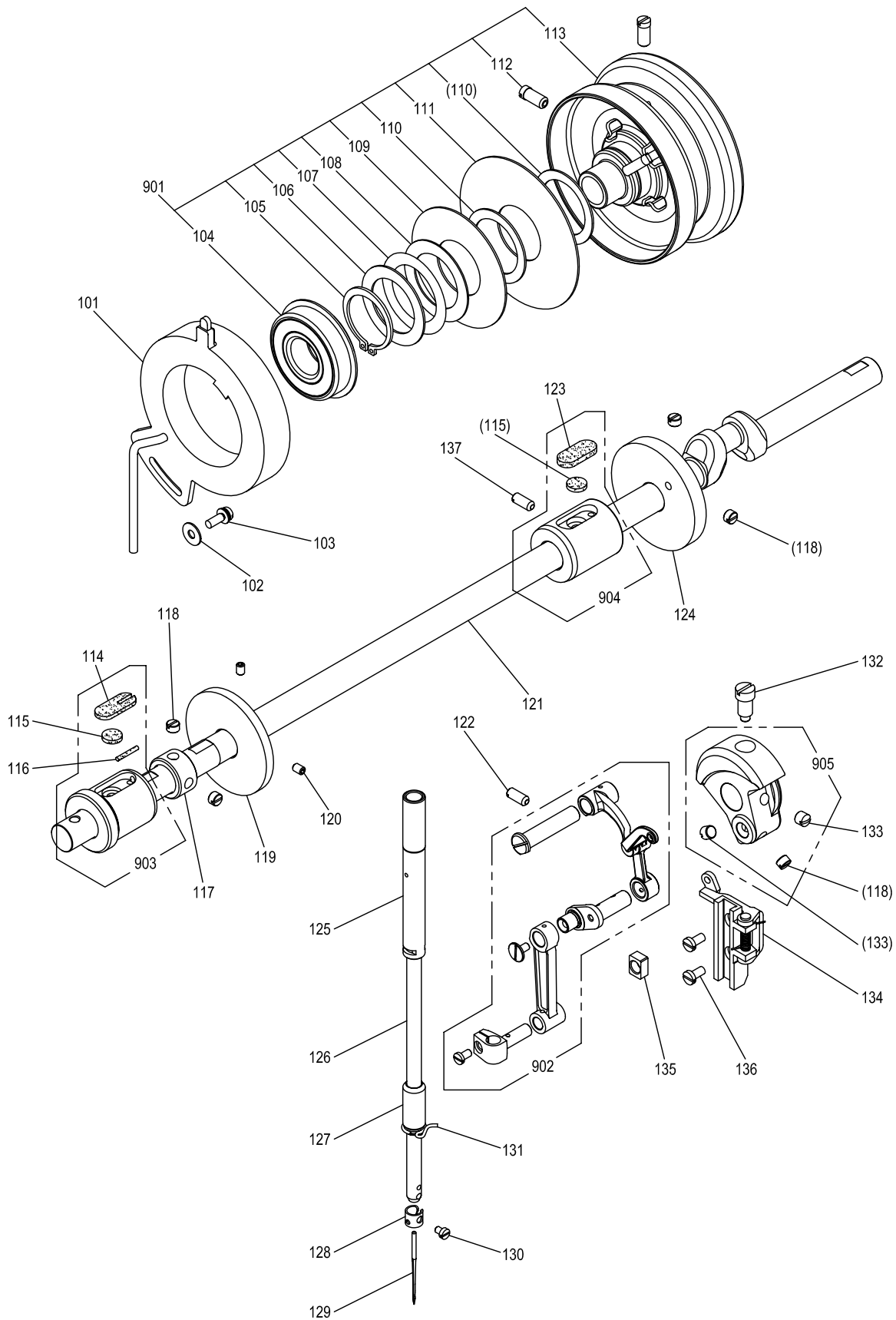

[D]縫い機構(1)

SEWING MECHANISM (1)

Fig no.	変更 Mod.	部品コード Parts no.	品名	Description	数量 Amt. Req.
D 101		MB60A2406	ウワジクケンシュツキ	Detector	1
D 102	B	M90421050	ザガネ 4	Washer 4	1
D 103	B	M91059004	SW-PWプラマイナヘネジ M4X12	Screw M4X12	1
D 104		MN10A1456	ボールベアリング	Ball bearing	1
D 105		M90330065	Cガ外メワ 30	C-type retaining ring 30	1
D 106		M93001050	ザガネ	Washer	1
D 107		MF01A0259	ナミザガネ	Wave washer	1
D 108		MF01A1476	スペーサー B	Spacer B	1
D 109		MN72A1694	ハンジャパン F20 (ウワイチ)	Command disk F20 (up)	1
D 110		MF01A0476	スペーサー A	Spacer A	2
D 111		MB60A0694	ハンジャパン K10 (シタイチ)	Command disk K10 (down)	1
D 112		M91520002	ヒラネジ 15/64(28)X12	Screw 15/64(28)X12	2
D 113		MB60E0682	プーリ	Pulley	1
D 114		MG50A0740	フェルト	Felt	1
D 115		MS10A1740	フェルト	Felt	2
D 116		MV88A0740	フェルト	Felt	1
D 117		MF70A0352	カラー	Collar	1
D 118		M91602001	トメネジ 1/4(40)X4	Screw 1/4(40)X4	5
D 119		MS14A0682	イトマキプーリ	Pulley	1
D 120		M91053020	ロッカクアナツキトメネジ M4X6	Screw M4X6	2
D 121		ME10A0230	ウワジク	Drive shaft	1
D 122		M91221001	トメネジ M5X12	Screw M5X12	1
D 123		MF60A2740	フェルト	Felt	1
D 124		MS01A0350	イトキリカム	Thread trimmer cam	1
D 125		MS01A0663	ハリホウメタル (ウエ)	Needle bar bushing (upper)	1
D 126		MS01A0660	ハリホウ	Needle bar	1
D 127		MG30A0664	ハリホウメタル (シタ)	Needle bar bushing (lower)	1
D 128		MF21D0181	イトアンナイ	Thread guide	1
D 129		MS02A0128	ミシンハリ DPX17#18	Needle DPX17#18	1
D 130		M90815002	ヒラネジ 1/8(44)X4.5	Screw 1/8(44)X4.5	1
D 131		MF01A0181	イトアンナイ	Thread guide	1
D 132		M91802006	ヒラネジホウサキ 9/32(28)	Set screw 9/32(28)	1
D 133		M91606001	トメネジ 1/4(40)X6	Screw 1/4(40)X6	2
D 134		MS03E0662	ハリカイトクミタテ	Guide assy	1
D 135		MF10A0325	カクコマ	Square block	1
D 136		M90990002	ヒラネジ M4X8	Screw M4X8	2
D 137	B	M91223001	トメネジ M5X10	Screw M5X10	1
D 901		MB60E1682	プーリクミタテ	Pulley assy	1
D 902		MS01E0580	テンビンハリクミタテ	Thread take-up lever assy	1
D 903		MS10A0232	ウワジクメタル(ヒタリ)クミ	Drive shaft bushing L assy	1
D 904		MB60E0234	ウワジクメタル(ナカ)クミ	Drive shaft bushing C assy	1
D 905		MS01A0383	クランククミ	Crank assy	1

E 縫い機構(2)
SEWING MECHANISM(2)

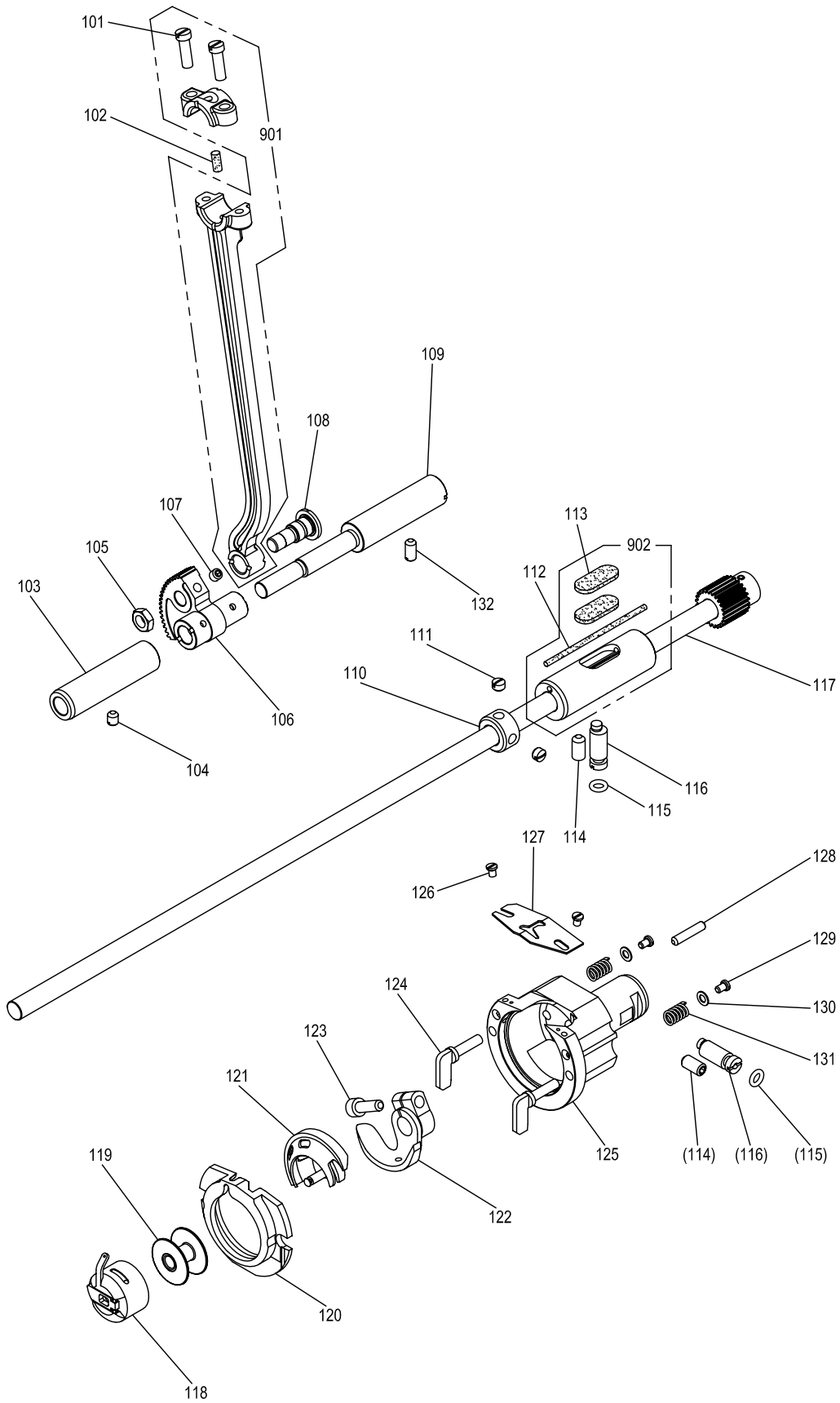

[E]縫い機構(2)

SEWING MECHANISM (2)

Fig no.	変更 Mod.	部品コード Parts no.	品名	Description	数量 Amt. Req.
E 101		M91203002	ヒラネジ 3/16(28)X15	Screw 3/16(28)X15	2
E 102		MB60A0740	フェルト	Felt	1
E 103		MS01A0833	メタル	Bushing	1
E 104	B	M91222001	トメネジ M5X6	Screw M5X6	1
E 105		M91802045	ナット 9/32(28)	Nut 9/32(28)	1
E 106		MS01A0508	セクタハゲルマ	Sector gear	1
E 107		M95004021	ロックアナツキトメネジ M5X5	Screw M5X5	1
E 108		M98003015	ヒラネジダツキ 9/32(28)	Screw 9/32(28)	1
E 109		MS01A0891	ヨウトウシク	Rock shaft	1
E 110		MM11A0352	カラー	Collar	1
E 111		M91503001	トメネジ 15/64(28)X4.5	Screw 15/64(28)X4.5	2
E 112		ME10A0148	ヒモ	Oil braid	1
E 113		MA20A0740	フェルト	Felt	2
E 114	B	M96002020	ロックアナツキトメネジ M6X12	Screw M6X12	2
E 115		M90500085	O リング	O-ring	2
E 116		MS01A0761	ヘンジンシク	Eccentric shaft	2
E 117		ME10E0450	シタジク クミ	Hook shaft assy	1
E 118		MS17A0125	ホビンケース SC-181	Bobbin case	1
E 119		MA10A0123	ホビン	Bobbin	1
E 120		MS08A0616	ナカガマオサエ	Hook retainer	1
E 121		MA10A0120	ナカガマ	Inner hook	1
E 122		MS01A0611	ドライバ	Hook driver	1
E 123		M95001021	ロックアナツキホルト M5X16	Bolt M5X16	1
E 124		MS09A0950	カマオサエツマミ	Hook clamp	2
E 125		MS01A0121	ソトガマ	Outer hook	1
E 126		M90853002	ヒラネジ 1/8(40)X4	Screw 1/8(40)X4	2
E 127		MS01A0329	カマイトアンナイ	Thread guide	1
E 128		M90001060	ヘイコウピン M6-4X18	Pin M6-4X18	1
E 129		M90802003	マルヒラネジ 1/8(44)X4.5	Screw 1/8(44)X4.5	2
E 130		M93006050	ワシガネ	Washer	2
E 131		MS01A0572	ツルマキハネ	Spring	2
E 132	B	M91221001	トメネジ M5X12	Screw M5X12	1
E 901		MB60E1956	レンセツカン クミ	Connecting rod assy	1
E 902		ME10E0452	シタジクメタル(ミキ)クミ	Hook shaft bushing (R) assy	1

F X-Yテーブル機構(1)
X-Y TABLE MECHANISM(1)

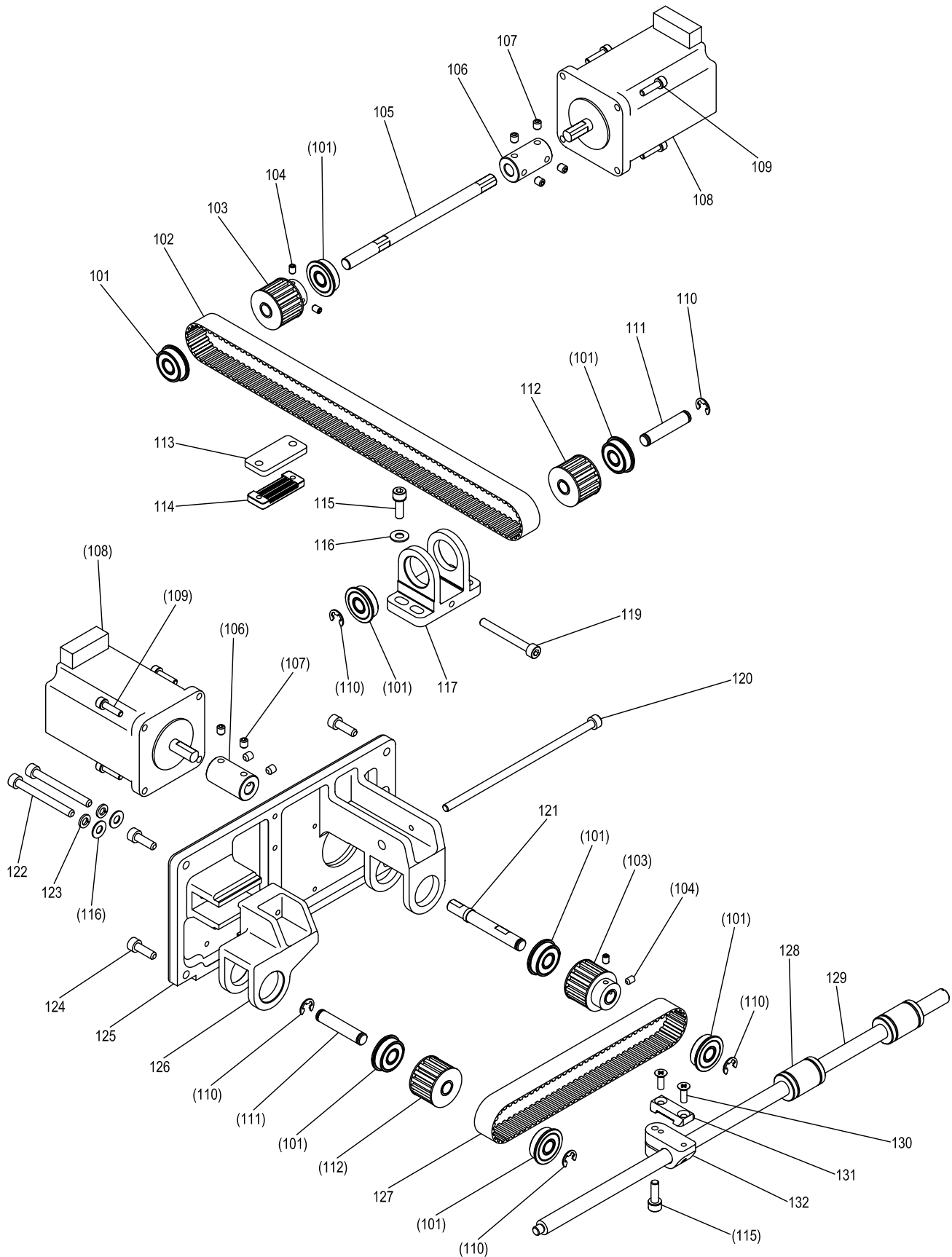

[F]X-Yテーブル機構(1)
X-Y TABLE MECHANISM (1)

Fig no.	変更 Mod.	部品コード Parts no.	品名	Description	数量 Amt. Req.
F 101		M91001075	ボールベアリング	Ball bearing	8
F 102		MB60A0523	タイミングベルト X	Cog belt X 15T5-630(126Z)	1
F 103		MB60A2682	タイミングプーリー (クドウ)	Driving pulley	2
F 104		M95001001	ナイロケットメネジ M4X6	Screw M4X6	4
F 105		ME10A1390	Xクドウジク	Driving shaft X	1
F 106		ME10A0571	ジクツキテ	Sleeve	2
F 107		M94001001	ナイロケットメネジ M5X6	Screw M5X6	8
F 108		M95060095	ステッピングモータ	Stepping motor	2
F 109		M94006017	セフティソケット M4X16	Bolt M4X16	8
F 110		M90511065	Eタイプメワ 6	E-type retaining ring 6	5
F 111		MB60A1454	ジク	Shaft	2
F 112		MB60A3682	タイミングプーリー (ジュウトウ)	Driven pulley	2
F 113		MB60A0476	スペーサ	Spacer	1
F 114		MB60A0778	ベルトオサエ X	Belt clamber X	1
F 115		M95004017	セフティソケット M5X16	Bolt M5X16	5
F 116		M90511050	ザガネ 5	Washer 5	6
F 117		MB60A1758	ブラケット X	Bracket X	1
F 119		M95035021	ロッククアナツキホルト M5X45	Bolt M5X45	1
F 120		M95036021	ロッククアナツキホルト M5X135	Bolt M5X135	1
F 121		ME10A0390	Yクドウジク	Driving shaft Y	1
F 122		M95048021	ロッククアナツキホルト M5X50	Bolt M5X50	2
F 123		M90504053	ハネザガネ 5	Spring washer 5	2
F 124	B	M95001017	セフティソケット M5X20	Bolt M5X20	4
F 125		ME10A0850	Yモータダイ	Motor bracket Y	1
F 126		ME10A0758	ブラケット Y	Bracket Y	1
F 127		ME10A0523	タイミングベルト Y	Cog belt Y 15T5-375(75Z)	1
F 128		M91003070	ボールブッシュ 10	Ball bushing 10	2
F 129		ME10A2390	Yクドウジク	Linear shaft Y	1
F 130		M90448037	Pサラネジ M4X12	Screw M4X12	2
F 131		ME10A0778	Yベルトオサエ	Belt clamber Y	1
F 132		MS14A0781	Yベルトダイ	Belt holder Y	1

G X-Yテーブル機構(2)
X-Y TABLE MECHANISM(2)

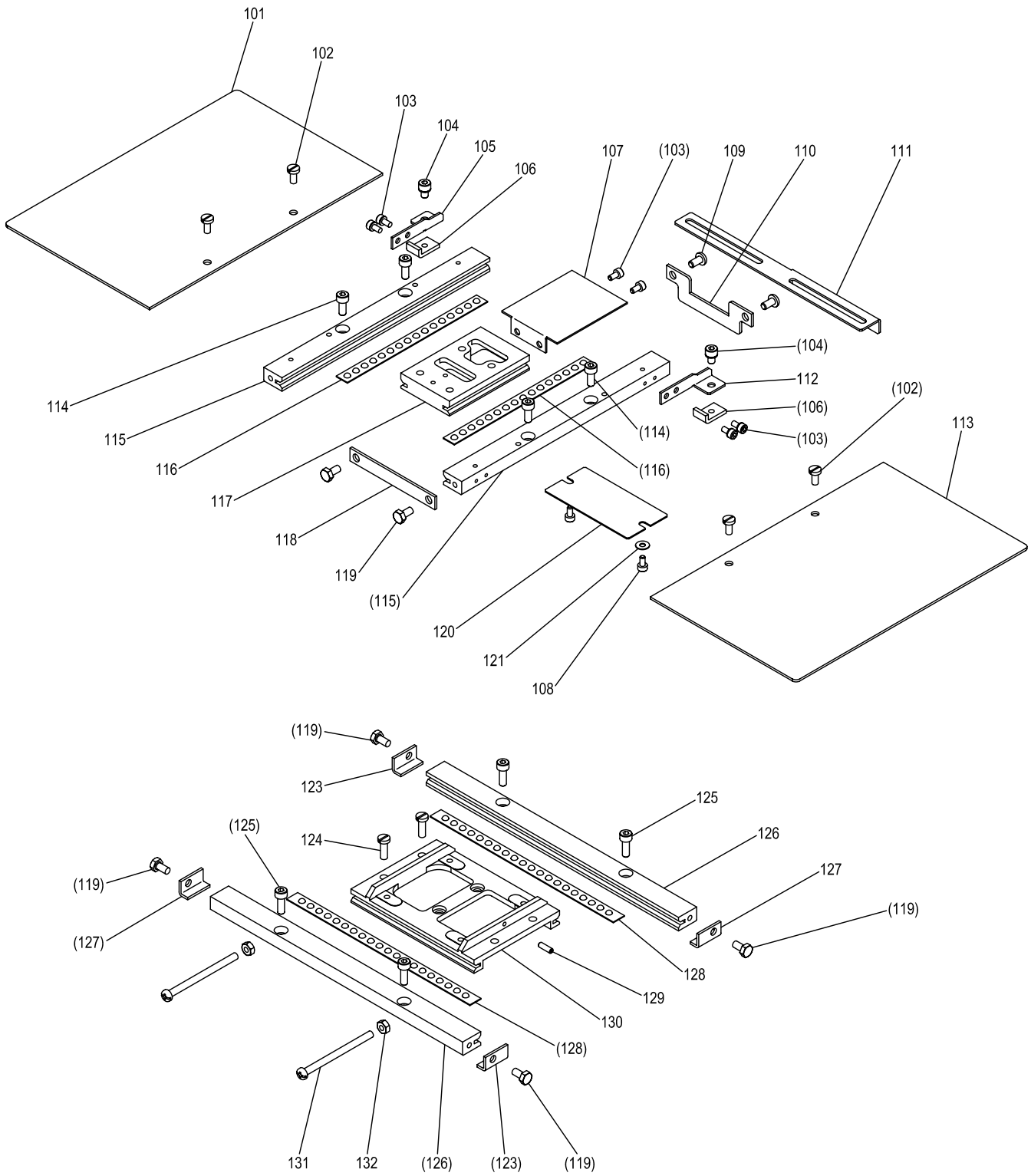

[G]X-Yテーブル機構(2)
X-Y TABLE MECHANISM (2)

Fig no.	変更 Mod.	部品コード Parts no.	品名	Description	数量 Amt. Req.
G 101		ME10A2339	カバー L	Cover L	1
G 102		M90921002	ヒラネジ 9/64(40)X8	Screw 9/64(40)X8	4
G 103		M94003017	セフテイツケット M3X6	Bolt M3X6	6
G 104		M94008017	セフテイツケット M4X6	Bolt M4X6	2
G 105		ME10A1426	ケンシュツハンササエ (L)	Detector holder L	1
G 106		MB60A2601	ネジイタ	Holder plate	2
G 107		ME10A4339	Yカバーイタ	Cover plate Y	1
G 108		M93003021	ロツカクアナツキホルト M3X6	Bolt M3X6	2
G 109		M94035021	ロツカクアナツキホルタンホルト M4X8	Bolt M4X8	2
G 110		ME10A0477	ストップ Y ウシロ	Rear stopper Y	1
G 111		MB60A0407	ケンシュツハン X	Detector plate X	1
G 112		ME10A0426	ケンシュツハンササエ (R)	Detector holder R	1
G 113		ME10A3339	カバー R	Cover R	1
G 114		M91060021	ロツカクアナツキホルト M4X10	Bolt M4X10	4
G 115		ME10A0957	Yジクコテイレース	Fixed race Y	2
G 116		ME10A0972	ローラーケージ Y	Roller cage Y	2
G 117		MS14A4957	Yジクコイトウレース	Movable race Y	1
G 118		MA04A0477	ストップ Y マエ	Front stopper Y	1
G 119		M91003022	ロツカクホルト M4X8	Bolt M4X8	6
G 120		ME10A5339	カバー	Cover	1
G 121		M90316050	ザガネ 3	Washer 3	2
G 123		MS02A3477	ストップ X	Stopper X	2
G 124		M90991002	ヒラネジ M4X12	Screw M4X12	2
G 125		M94003021	ロツカクアナツキホルト M4X12	Bolt M4X12	4
G 126		MB60A0957	Xジクコテイレース	Fixed race X	2
G 127		MS02A4477	ストップ X	Stopper X	2
G 128		MS14A0972	ローラーケージ X	Roller cage X	2
G 129		M93007020	ロツカクアナツキトメネジ M3X10	Screw M3X10	1
G 130		MB60A1957	Xジクコイトウレース	Movable race X	1
G 131		M91083004	プラマイナヘネジ M4X55	Screw M4X55	2
G 132		M91004045	ナット M4	Nut M4	2

H 外押え機構(1)
 WORK HOLDER MECHANISM(1)

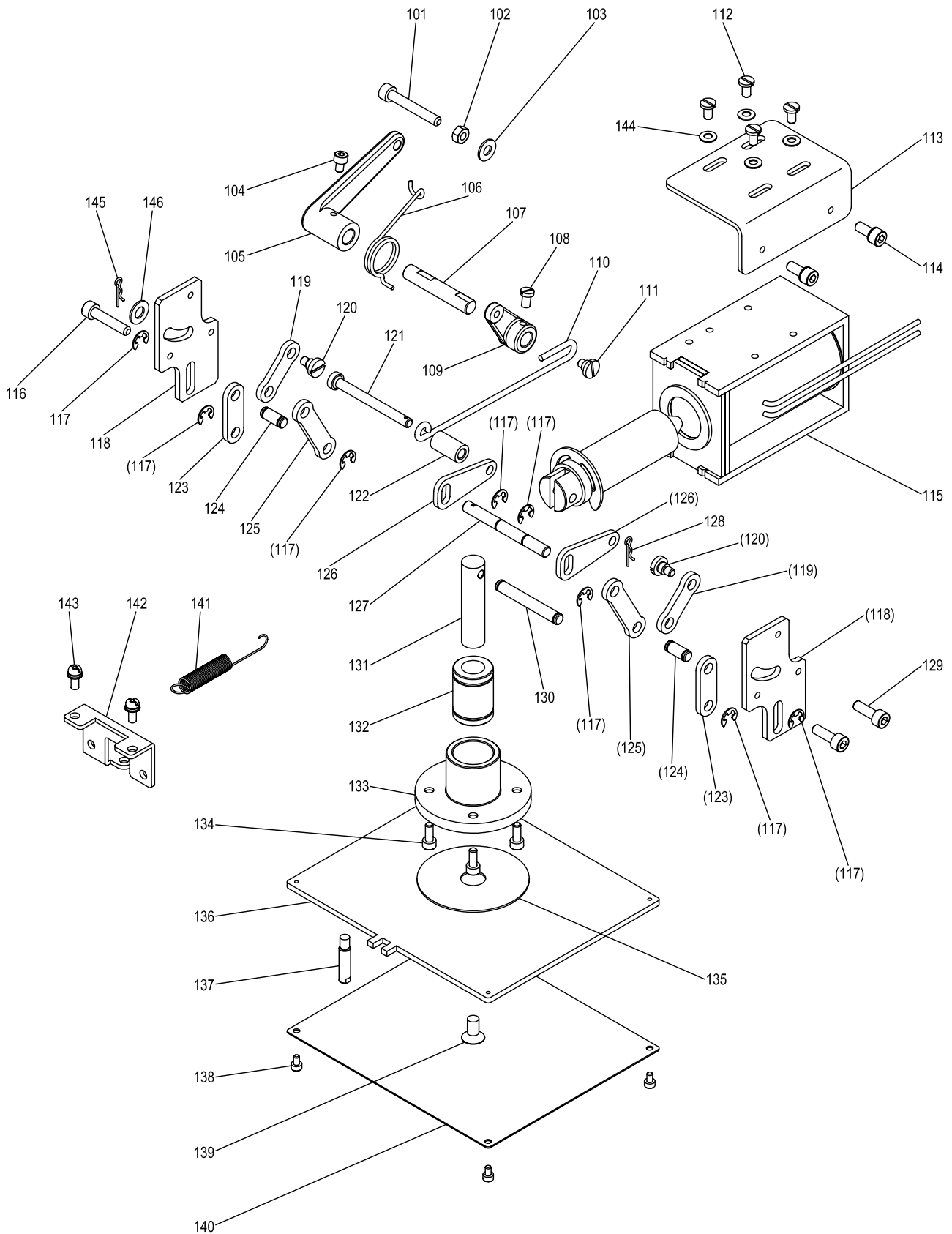

[H]外押え機構(1)

WORK HOLDER MECHANISM (1)

Fig no.	変更 Mod.	部品コード Parts no.	品名	Description	数量 Amt. Req.
H 101		M95008021	ロックアナツキボルト M5X35	Bolt M5X35	1
H 102		M91382045	ナット M5	Nut M5	1
H 103		M90511050	ザガネ 5	Washer 5	1
H 104		M94001021	ロックアナツキボルト M4X6	Bolt M4X6	1
H 105		MA10A0950	レバー	Lever	1
H 106		MA10A0729	ヒネリハネ	Spring	1
H 107		MA10A0454	ジク	Shaft	1
H 108		M91109002	ヒラネジ 11/64(40)X7	Screw 11/64(40)X7	1
H 109		MA10A1950	レバー	Lever	1
H 110		ME10A1910	リンク	Link	1
H 111		M91137015	ヒラネジダツキ 11/64(40)	Screw 11/64(40)	1
H 112		M91116002	ヒラネジ 11/64(40)X8	Screw 11/64(40)X8	4
H 113		ME10A1758	ブラケット	Bracket	1
H 114	B	M95002017	セフティソケット M5X12	Bolt M5X12	2
H 115		ME10E0519	ソレノイドクミタテ	Solenoid assy	1
H 116		M95011021	ロックアナツキボルト M5X25	Bolt M5X25	2
H 117		M90505065	Eタイプメワ 5	E-type retaining ring 5	8
H 118		ME10A0743	ガイドプレート	Guide plate	2
H 119		ME10A3910	リンク A	Link A	2
H 120		M91127015	ヒラネジダツキ 11/64(40)	Screw 11/64(40)	2
H 121		M90543060	ピン	Pin	1
H 122		ME10A0352	カラー	Collar	1
H 123		ME10A2910	リンク B	Link B	2
H 124		M90619060	ピン C	Pin C	2
H 125		ME10A4910	リンク C	Link C	2
H 126		ME10A5910	リンク S	Link S	2
H 127		M90618060	ピン A	Pin A	1
H 128		M90518060	スナップピン R5	Snap pin R5	1
H 129		M95001021	ロックアナツキボルト M5X16	Bolt M5X16	2
H 130		M90620060	ピン E	Pin E	1
H 131		ME10A0454	オサエジク	Shaft	1
H 132		M96001070	ボールブッシュ 12	Ball bushing 12	1
H 133		ME10A0267	オサエイタメタル	Bushing	1
H 134	B	M95018021	ロックアナツキボルト M4X8	Bolt M4X8	4
H 135		MS14A0416	カンショウイタ	Cushion	1
H 136		ME10A0257	オサエイタ	Pressure plate	1
H 137		ME10A0802	マワリドメ	Guide pin	1
H 138		M93004021	ロックアナツキボルト M3X5	Bolt M3X5	4
H 139		M96033021	ロックアナツキサラボルト M6X12	Bolt M6X12	1
H 140		ME10A8339	スライドカバー	Slide cover	1
H 141	B	ME10A1572	ツルマキハネ	Spring	1
H 142		MB60A0780	ホルダー	Holder	1
H 143	B	M91054004	SW-PWプラマイナヘネジ M4X8	Screw M4X8	2
H 144	B	M90110053	サラハネザガネ 1L-4	Spring washer 1L-4	4
H 145	B	M90105062	スナップピン R5	Snap pin R5	1
H 146	B	M90631050	ザガネ 6	Washer 6	1

J 外押え機構(2)
 WORK HOLDER MECHANISM(2)

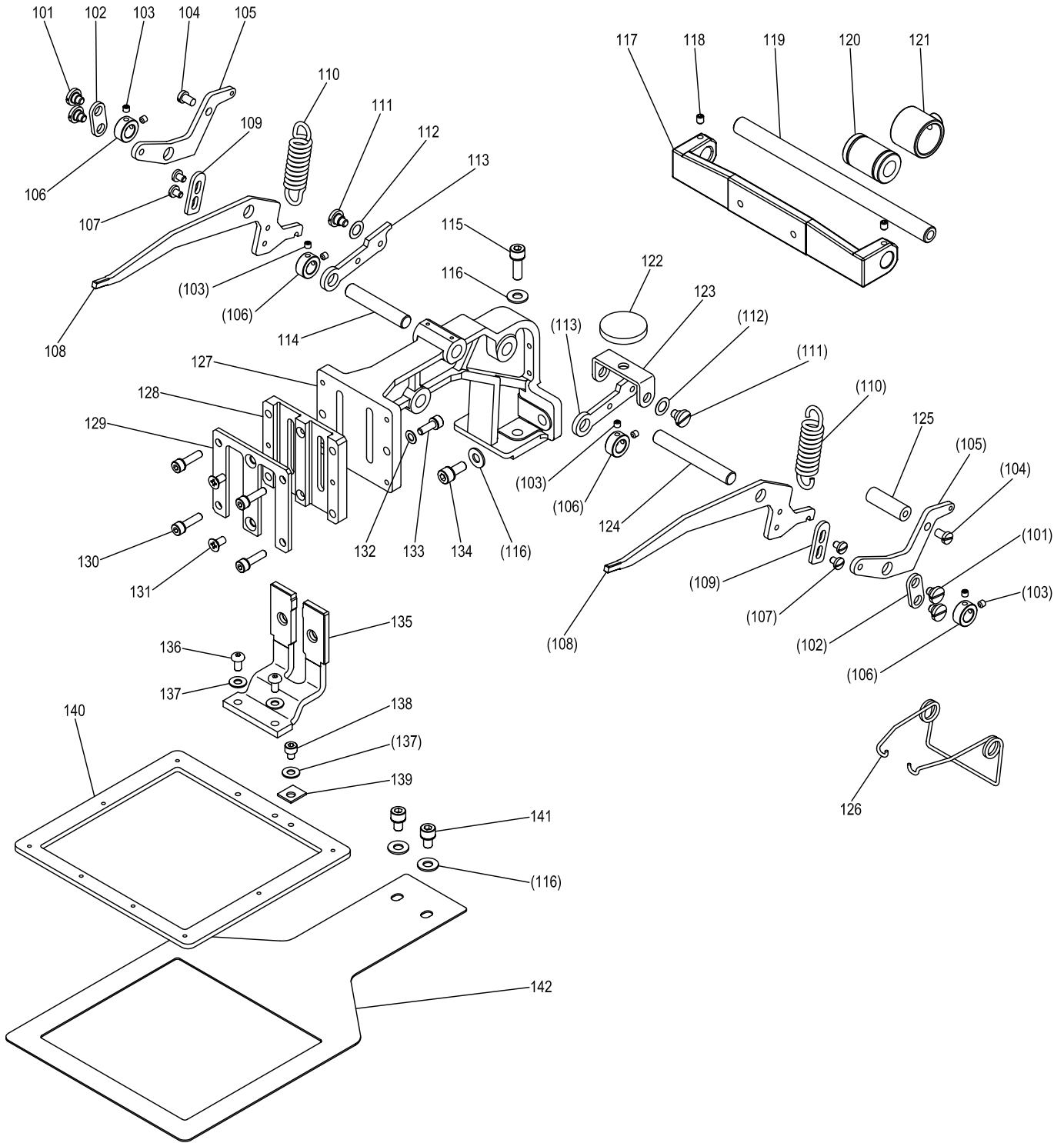

[J]外押え機構(2)

WORK HOLDER MECHANISM (2)

Fig no.	変更 Mod.	部品コード Parts no.	品名	Description	数量 Amt. Req.
J 101		M91139015	ヒラネジ [°] タンツキ 11/64(40)·····	Screw 11/64(40)·····	4
J 102		ME10A0910	リンク·····	Link·····	2
J 103		M90901020	ロッカクアナツキメネジ [°] 9/64(40)X3.5·····	Screw 9/64(40)X3.5·····	8
J 104		M91109002	ヒラネジ [°] 11/64(40)X7·····	Screw 11/64(40)X7·····	2
J 105		ME10A0429	ササエイタ·····	Pressure lever B·····	2
J 106		MF00A1352	カラー·····	Collar·····	4
J 107		M90943002	マルヒラネジ [°] 9/64(40)X5·····	Screw 9/64(40)X5·····	4
J 108		ME10A0266	オサエレバ [°] ·····	Pressure lever A·····	2
J 109		MB60A0477	ストップパ [°] ·····	Stopper·····	2
J 110		ME10A0700	ツルマキパ [°] ネ·····	Spring·····	2
J 111		M91137015	ヒラネジ [°] タンツキ 11/64(40)·····	Screw 11/64(40)·····	2
J 112		M99002052	ウェーブワッシャ 1417003-41006·····	Wave washer 1417003-41006·····	2
J 113		ME10A1266	オサエレバ [°] ·····	Pressure lever C·····	2
J 114		M90817060	ピン L=46·····	Pin L=46·····	1
J 115		M95004017	セフティソケット M5X16·····	Bolt M5X16·····	2
J 116		M90511050	ザ [°] ガネ 5·····	Washer 5·····	6
J 117		MA10A0455	ジクササエ·····	Bracket·····	1
J 118		M91050020	ロッカクアナツキメネジ [°] M4X5·····	Screw M4X5·····	2
J 119		MS14A4454	ジク·····	Shaft·····	1
J 120		M91003070	ボールブッシュ 10·····	Ball bushing 10·····	1
J 121		MS08A0692	ジクウケハウジング·····	Bearing housing·····	1
J 122		ME10A0457	シュウトウシ·····	Slider·····	1
J 123		ME10A1601	トリツケイタ·····	Bracket·····	1
J 124		M90818060	ピン L=60·····	Pin L=60·····	1
J 125		ME10A1454	レンケツジク·····	Connecting shaft·····	1
J 126		ME10A0729	ヒネリパ [°] ネ·····	Spring·····	1
J 127		ME10A0308	オサエダイ·····	Work holder arm·····	1
J 128		ME10A0307	オサエアンナイ·····	Work holder guide·····	1
J 129		ME10A6339	カバー·····	Cover·····	1
J 130		M94006017	セフティソケット M4X16·····	Bolt M4X16·····	4
J 131		M91400010	Pサラネジ [°] M4X8·····	Screw M4X8·····	2
J 132		M90422050	ザ [°] ガネ 4·····	Washer 4·····	2
J 133		M94007017	セフティソケット M4X12·····	Bolt M4X12·····	2
J 134		M95002017	セフティソケット M5X12·····	Bolt M5X12·····	2
J 135		ME10A0601	オサエトリツケイタ·····	Clamp foot·····	1
J 136		M94035021	ロッカクアナツキホ [°] タンホルト M4X8·····	Bolt M4X8·····	2
J 137		M90421050	ザ [°] ガネ 4·····	Washer 4·····	3
J 138		M94009021	ロッカクアナツキホ [°] ルト M4X5·····	Bolt M4X5·····	1
J 139		MB60A0196	イチキ [°] メイタ·····	Clamp stopper·····	1
J 140		ME10A0105	オサエ·····	Clamp frame·····	1
J 141	B	M95005017	セフティソケット M5X10·····	Bolt M5X10·····	2
J 142		ME10A0272	オクリイタ·····	Feed plate·····	1

K 糸切り機構
THREAD TRIMMING MECHANISM

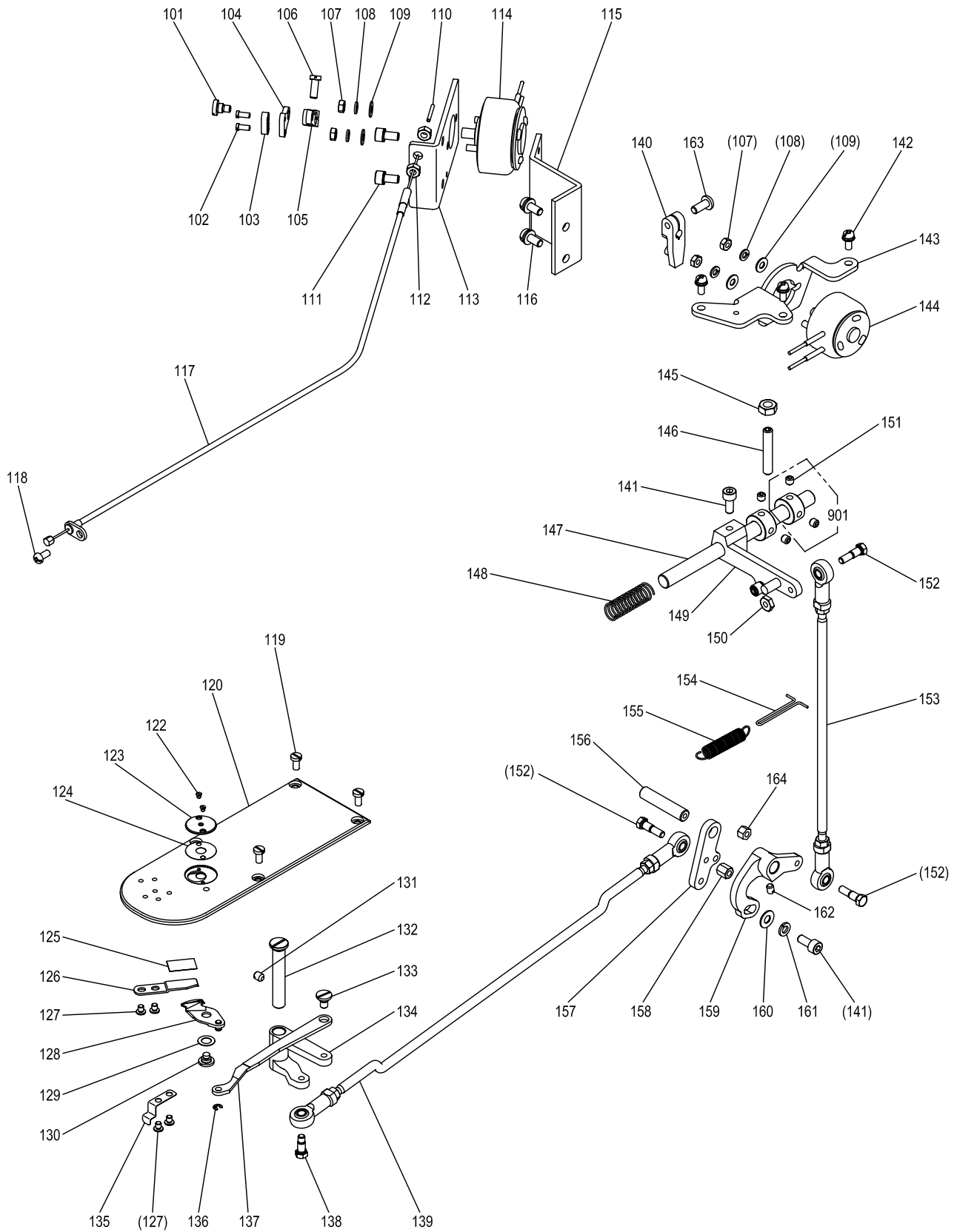

[K]糸切り機構

THREAD TRIMMING MECHANISM

Fig no.	変更 Mod.	部品コード Parts no.	品名	Description	数量 Amt. Req.
K 101		M91127015	ヒラネジ [◇] ダンツキ 11/64(40)	Screw 11/64(40)	1
K 102		M90802002	ヒラネジ [◇] 1/8(44)X7	Screw 1/8(44)X7	2
K 103		MF36A0750	ホルダ	Holder	1
K 104		MF90A0361	カケガネ	Bracket	1
K 105		MS07A0228	ウテ	Crank	1
K 106		M91112002	ヒラネジ [◇] 11/64(40)X12	Screw 11/64(40)X12	1
K 107		M91004045	ナット M4	Nut M4	4
K 108		M90424053	バネサガネ 4	Spring washer 4	4
K 109		M90421050	サガネ 4	Washer 4	4
K 110		MN60A0750	ブッシュ	Pipe	1
K 111		M95005017	セフテソケット M5X10	Bolt M5X10	2
K 112		M91382045	ナット M5	Nut M5	2
K 113		MA20A0603	ソレノイドトリツケイタ	Solenoid bracket	1
K 114		ME10E3519	イトクルメソレノイド	Solenoid (thread release)	1
K 115		MA10A0601	トリツケイタ	Bracket	1
K 116		M91331004	SW-PW [◇] プラマイナ [◇] ネジ [◇] M5X12	Screw M5X12	2
K 117		ME10E0746	フレキシブルワイヤ	Flexible wire assy	1
K 118	B	M91069004	プラマイナ [◇] ネジ [◇] M4X8	Screw M4X8	1
K 119		M90990002	ヒラネジ [◇] M4X8	Screw M4X8	4
K 120	B	MS14A0472	スベリイタ (ナカ)	Slide plate (center)	1
K 122		M90605010	サラネジ [◇] 3/32(56)X2.8	Screw 3/32(56)X2.8	2
K 123		MS03A1101	ハリイタ φ2.2	Needle plate	1
K 124		MS01A1476	スペーサー	Spacer	1
K 125		MA10B2476	スペーサー	Spacer	1
K 126		MS14A0838	コテイメス	Fixed knife	1
K 127		M90906003	マルヒラネジ [◇] 9/64(40)X3.2	Screw 9/64(40)X3.2	4
K 128		MS03B0838	イトウメス	Movable knife	1
K 129		M96004052	ウェーブワッシャ 6	Wave washer 6	1
K 130		M91129015	ヒラネジ [◇] ダンツキ 11/64(40)	Screw 11/64(40)	1
K 131	B	M91224001	トメネジ [◇] M5X8	Screw M5X8	1
K 132		MS01A5454	ツバツクジク	Stepped pin	1
K 133		M91214015	ヒラネジ [◇] ダンツキ 3/16(28)	Screw 3/16(28)	1
K 134		MA20A0392	メスクト [◇] ウウテ [◇] (3)	knife driving crank (3)	1
K 135		MS01A0192	イタハネ	Leaf spring	1
K 136		M90513065	E [◇] カ [◇] 外 [◇] メ [◇] ワ 2.5	E-type retaining ring 2.5	1
K 137		MS03A1910	リンク	Link	1
K 138		M90102017	ホルトダンツキ 11/64(40)	Bolt 11/64(40)	1
K 139		ME10E0975	ロッド [◇] エント [◇] クミ [◇] タテ (ヨコ)	Connecting rod (horizontal)	1
K 140		MS01E0430	イトキリサド [◇] ウウテ [◇]	Crank	1
K 141		M95003021	ロッカクアナツキホルト M5X12	Bolt M5X12	2
K 142		M91056004	SW-PW [◇] プラマイナ [◇] ネジ [◇] M4X10	Screw M4X10	3
K 143		MS14A3601	ソレノイドトリツケイタ	Solenoid bracket	1
K 144		ME10E2519	イトキリソレノイド	Solenoid (thread trim)	1
K 145		M91576045	ナット M6	Nut M6	1
K 146		M91652020	コネジ [◇] M6X35	Screw M6X35	1
K 147		MS01A0348	カムシク	Shaft	1
K 148		MS01A1572	ツルマキハネ	Spring	1
K 149		MS01E0351	カムツイシユウウテ [◇] クミ	Cam follower assy	1
K 150		M91104045	ナット 11/64(40)	Nut 11/64(40)	1
K 151		M95004021	ロッカクアナツキトメネジ [◇] M5X5	Screw M5X5	4
K 152		M90101017	ホルトダンツキ 11/64(40)	Bolt 11/64(40)	3
K 153		MS01E0975	ロッド [◇] エント [◇] クミ [◇] タテ (タテ)	Connecting rod (vertical)	1
K 154		MS08A0708	ハネカケ	Hook	1
K 155		MS01A2572	ツルマキハネ	Spring	1
K 156		MS08A0454	シク	Shaft	1
K 157		MS01A2392	メスクト [◇] ウウテ [◇] (2)	knife driving crank (2)	1
K 158		M91109045	ロングナット 11/64(40)	Long nut 11/64(40)	1
K 159		MS01A1392	メスクト [◇] ウウテ [◇] (1)	knife driving crank (1)	1
K 160		M90511050	サガネ 5	Washer 5	1
K 161		M90504053	バネサガネ 5	Spring washer 5	1
K 162		M91108001	トメネジ [◇] 11/64(40)X5.5	Screw 11/64(40)X5.5	1
K 163	B	M95049021	ロッカクアナツキホルト [◇] タン [◇] ホルト M5X12	Molt M5X12	1
K 164	B	M91102045	ナット 11/64(40)	Nut 11/64(40)	1
K 901		MS01A3352	カラー [◇] クミ	Collar assy	2

L 中押え機構
PRESSER BAR LIFTING MECHANISM

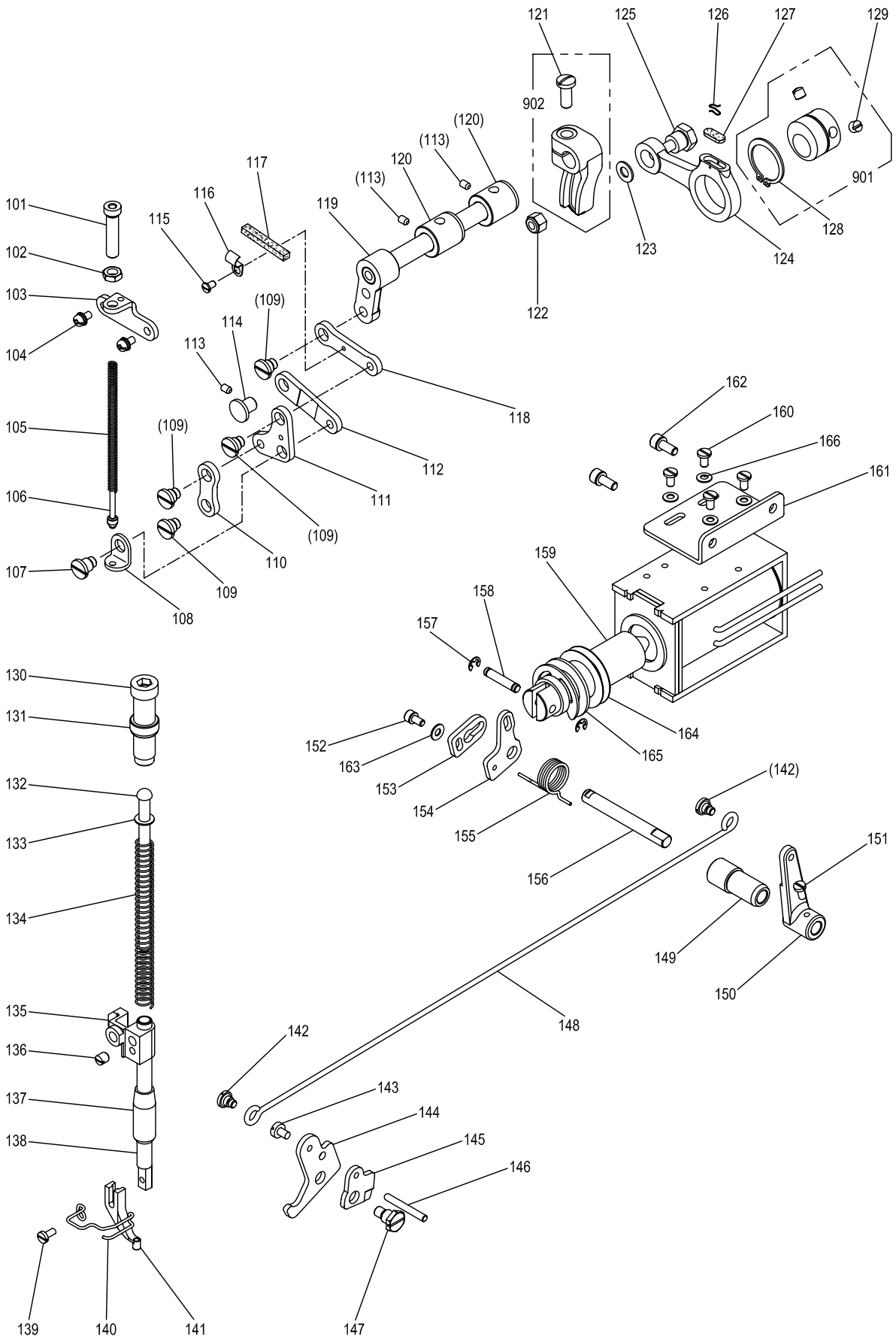

[L]中押え機構

PRESSER BAR LIFTING MECHANISM

Fig no.	変更 Mod.	部品コード Parts no.	品名	Description	数量 Amt. Req.
L 101		M91801035	ツミネジ 9/32(28)X35	Thumb screw 9/32(28)X35	1
L 102		M91802045	ナット 9/32(28)	Nut 9/32(28)	1
L 103		ME10A0261	オサエジョウセツダイ	Bracket	1
L 104	B	M91056004	SW-PWフライナベネジ M4X10	Screw M4X10	2
L 105		ME10A0572	ツルマキハネ	Spring	1
L 106		MS03A6154	アンナイガネ	Spring guide bar	1
L 107		M91689015	ヒラネジダンツキ 1/4(40)	Screw 1/4(40)	1
L 108		MG30B0226	オサエイタササエ	Supporter	1
L 109		M91688015	ヒラネジダンツキ 1/4(40)	Screw 1/4(40)	4
L 110		ME10A6910	リンク	Link	1
L 111		ME10A0763	ベルクランク	Bell crank	1
L 112		ME10A7910	リンク	Link	1
L 113	B	M91058020	ロッカクアナツキトメネジ M4X10	Screw M4X10	3
L 114		M99006063	ツバツキシク	Pin	1
L 115		M90908003	マルヒラネジ 9/64(40)X6	Screw 9/64(40)X6	1
L 116		MN70A1780	ホルダ	Holder	1
L 117		MG30A0740	フェルト	Felt	1
L 118		ME10A1956	レンセツカン	Link	1
L 119		MS02E0460	ウデクミタテ	Arm shaft assy	1
L 120		MG30A0833	メタル	Bushing	2
L 121		M91603003	マルヒラネジ 1/4(40)X16	Screw 1/4(40)X16	1
L 122		M91572045	U ナット 6X0.75	U-nut 6X0.75	1
L 123		M90631050	ザガネ 6	Washer 6	1
L 124		ME10A0956	レンセツカン	Crank rod	1
L 125		M91551015	ホルトダンツキ M6	Bolt M6	1
L 126		MF60A0700	センサイクハネ	Holder	1
L 127		MG30B0740	フェルト	Felt	1
L 128		M90325065	Cガ外メワ 25	C-type retaining ring 25	1
L 129		M91606001	トメネジ 1/4(40)X6	Screw 1/4(40)X6	2
L 130		M93202045	ツミネジ 1/2(28)X43	Thumb screw 1/2(28)X43	1
L 131		M93202047	ナット 1/2(28)	Nut 1/2(28)	1
L 132		MS03A0703	アンナイホウ	Presser bar guide	1
L 133		M90632050	コザガネ 6	Washer 6	1
L 134		MS03A1572	ツルマキハネ	Spring	1
L 135		MG75A0265	オサエホウダキ	Presser bar holder	1
L 136		M91506001	トメネジ 15/64(28)X6	Screw 15/64(28)X6	1
L 137		MF10A0267	オサエホウメタル	Bushing	1
L 138		MS03A0262	オサエホウ	Presser bar	1
L 139		M90922002	ヒラネジ 9/64(40)X8	Screw 9/64(40)X8	1
L 140		MB60A1626	ニートルガード	Needle guard	1
L 141		MV30A0256	オサエ φ3	Presser foot φ3	1
L 142		M91219015	ヒラネジダンツキ 3/16(28)	Screw 3/16(28)	2
L 143		M91131002	ヒラネジ 11/64(40)X6.5	Screw 11/64(40)X6.5	1
L 144		ME10A1252	オサエアケレバ	Lifting lever	1
L 145		MF70A0350	イトルメカム	Plate cam	1
L 146		M90423060	イトルメピン	Pin	1
L 147		M91515022	ホルトダンツキ 15/64(28)	Bolt 15/64(28)	1
L 148		ME10A0738	ヒキホウ	Link	1
L 149		ME10A0833	メタル	Bushing	1
L 150		ME10A0950	レバ	Lever	1
L 151		M90990002	ヒラネジ M4X8	Screw M4X8	1
L 152	B	M94002017	セフティソケット M4X8	Bolt M4X8	1
L 153	B	ME10A1810	マワリトメタ	Holder	1
L 154	B	ME10A2252	オサエアケレバ	Lifting lever	1
L 155		ME10A1729	ヒネリハネ	Spring	1
L 156		ME10A2454	ジク	Shaft	1
L 157		K14S92221040	Eガ外メワ 4	E-type retaining ring 4	2
L 158		M90432060	ピン	Pin	1
L 159		ME10E1519	ソレノイドクミタテ	Solenoid assy	1
L 160		M91116002	ヒラネジ 11/64(40)X8	Screw 11/64(40)X8	4
L 161		ME10A2601	ソレノイドトリツケイタ	Bracket	1
L 162		M95002017	セフティソケット M5X12	Bolt M5X12	2
L 163	B	M90421050	ザガネ 4	Washer 4	1
L 164	B	M92004050	ジョウオンワッシャ	Washer	2
L 165	B	M92003050	ジョウオンワッシャ	Washer	1
L 166	B	M90110053	サラバネサガネ 1L-4	Spring washer 1L-4	4
L 901		MG30A0760	ヘンシンリンクミタテ	Eccentric cam assy	1
L 902		MS02A0463	ウデ(ミキ)	Arm (right)	1

M ワイパー機構
WIPER MECHANISM

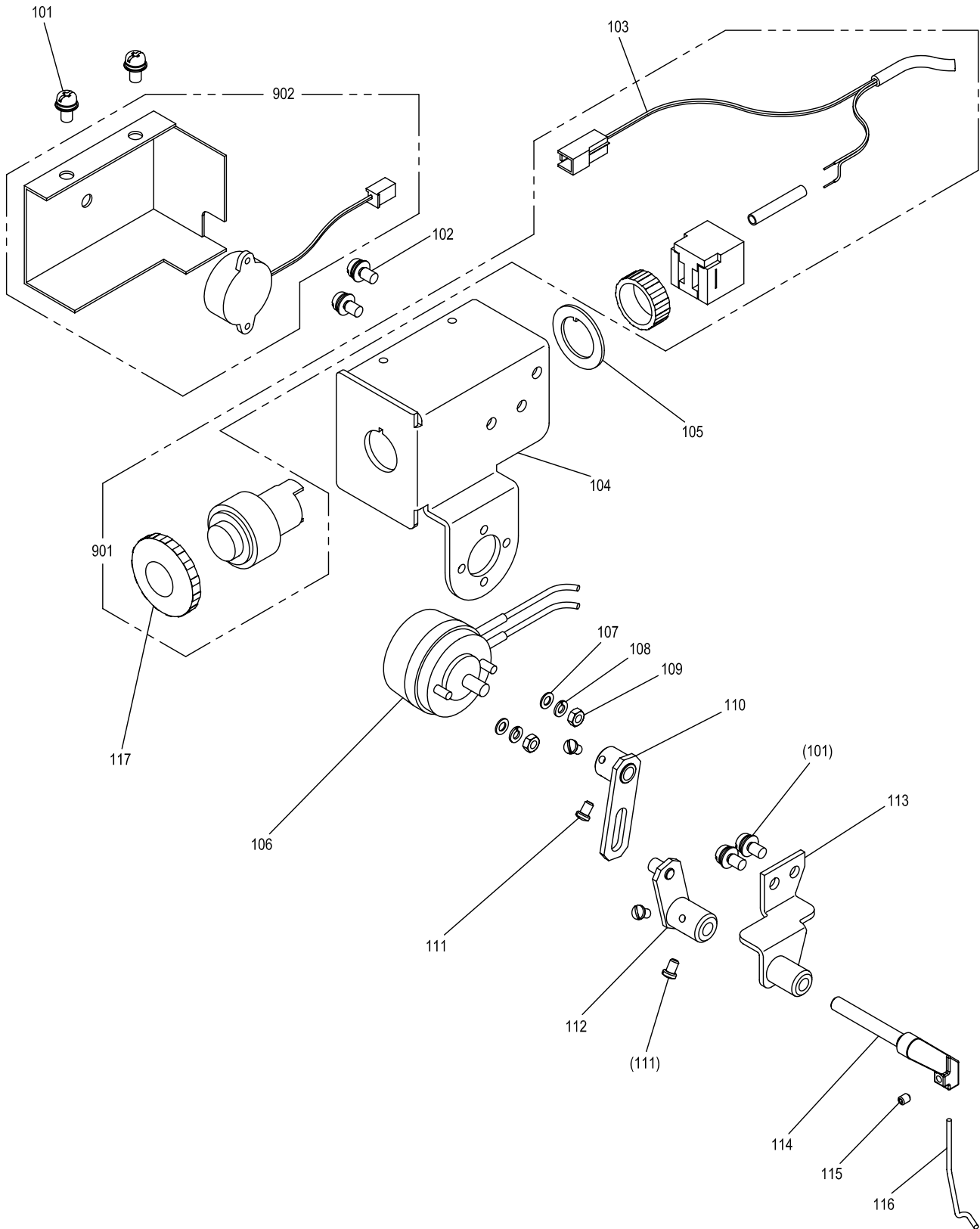

[M]ワイパー機構
WIPER MECHANISM

Fig no.	変更 Mod.	部品コード Parts no.	品名	Description	数量 Amt. Req.
M 101	B	M91054004	SW-PWプラマイナヘネジ M4X8	Screw M4X8	4
M 102	B	M91056004	SW-PWプラマイナヘネジ M4X10	Screw M4X10	2
M 103		M97356099	セツクデンセン	Cable (stop BZ)	1
M 104		ME10E3601	トリツケイタ	Bracket	1
M 105		MB60A0915	ロックリング	Lock ring	1
M 106		ME10E4519	ワイパソレノイド	Solenoid (wiper)	1
M 107		M90317050	ザガネ 3	Washer 3	2
M 108		M90307053	ハネザガネ 3	Spring washer 3	2
M 109		M90875045	ナット M3	Nut M3	2
M 110		MS02E0983	クドウイタ	Wiper crank 1	1
M 111		M90802003	マルヒラネジ 1/8(44)X4.5	Screw 1/8(44)X4.5	4
M 112		MS03E0981	ジュウトウイタ	Wiper crank 2	1
M 113		MB60E0982	ワイパダイ	Wiper adapter	1
M 114		MS03A1530	ワイパシク	Wiper shaft	1
M 115		M91057020	ロックアナツキメネジ M3X4	Screw M3X4	1
M 116		MS03A3980	ワイパ	Wiper	1
M 117	B	ME03A0270	プッシュボタン	Push button	1
M 901		ME10E0270	オンボタンスイッチミ	Switch assy	1
M 902		MB60E3339	カバークミ (ブザーツキ)	Cover assy (with buzzer)	1

N 給油機構
OIL LUBRICATION MECHANISM

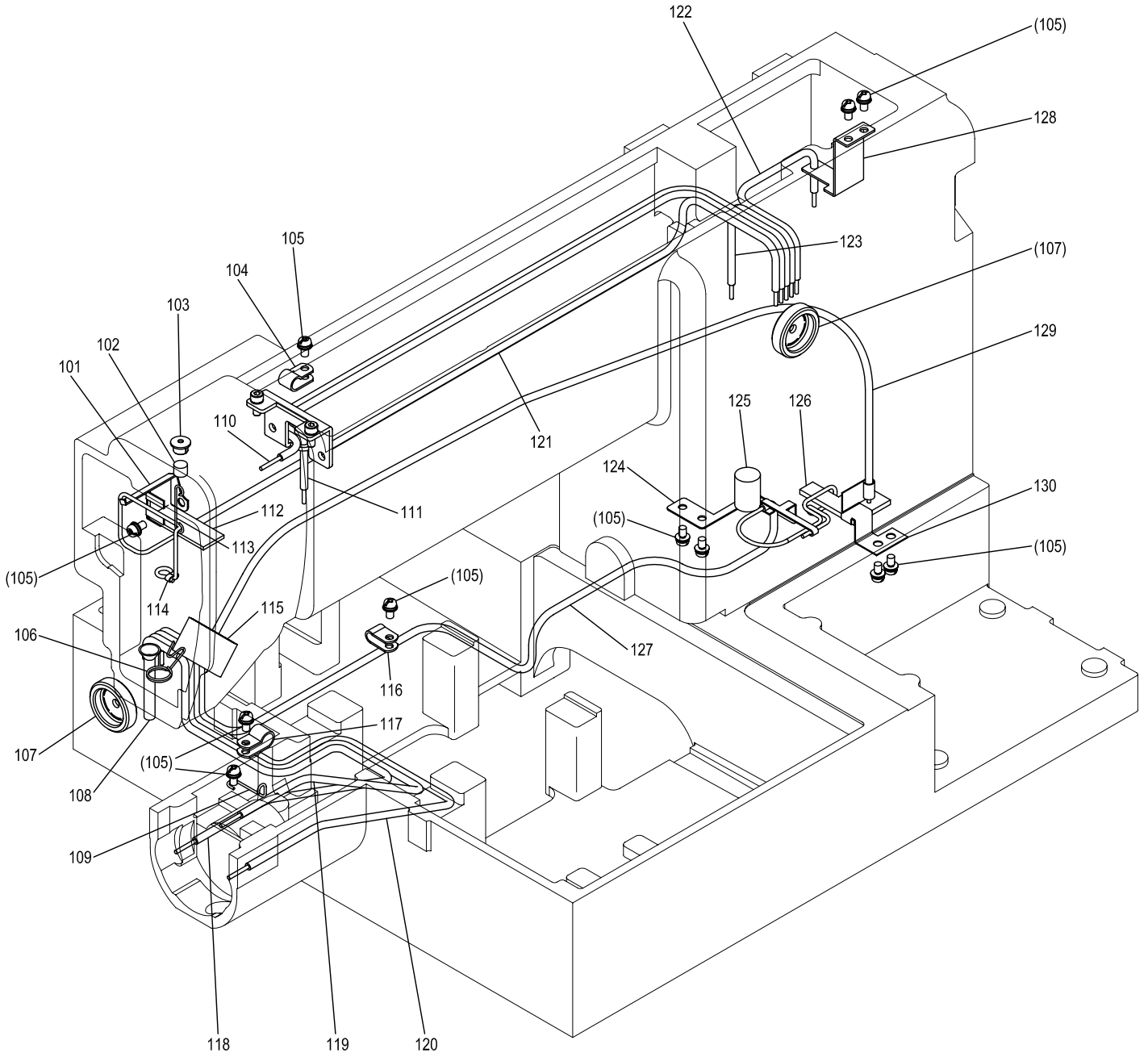

From the library of: Diamond Needle Corp

[N]給油機構

OIL LUBRICATION MECHANISM

Fig no.	変更 Mod.	部品コード Parts no.	品名	Description	数量 Amt. Req.
N 101		ME10A1780	ホルダ	Holder	1
N 102		MF10A2740	フェルト	Felt	1
N 103		MF60A0742	フタ	Cap	1
N 104		M94004099	ナイロンクリップ AB-4N	Nylon clip AB-4N	1
N 105		M91054004	SW-PWプラスマイナネジ M4X8	Screw M4X8	11
N 106		MF00A2780	ホルダ	Holder	1
N 107		MN10A0135	オイルゲージ	Oil gauge	2
N 108		MS10A0688	パイプ (アルミ)	Pipe	1
N 109		MS01A8796	ホルダ	Holder	1
N 110		ME10E1688	パイプヒモクミ (ウワジクメタル マエ)	Oil pipe assy (drive shaft bushing F)	1
N 111		ME10E2688	パイプヒモクミ (ヘンシンリン)	Oil pipe assy (eccentric cam)	1
N 112		MS01A1740	フェルト	Felt	1
N 113		MS03A2780	ホルダ	Holder	1
N 114		MF80A0780	ホルダ	Holder	1
N 115		MS01A0740	フェルト	Felt	1
N 116		M94003099	ナイロンクリップ AB-3N	Nylon clip AB-3N	1
N 117		MN60A0620	ナイロンクリップ AB-5N	Nylon clip AB-5N	1
N 118		ME10E3688	パイプヒモクミ (カマ ヒタリ)	Oil pipe assy (hook left)	1
N 119		ME10E4688	パイプヒモクミ (カマ ナカ)	Oil pipe assy (hook center)	1
N 120		ME10E5688	パイプヒモクミ (カマ ミキ)	Oil pipe assy (hook right)	1
N 121		ME10E6688	パイプヒモクミ (ハリホウ)	Oil pipe assy (needle bar)	1
N 122		ME10E7688	パイプヒモクミ (レンセツカン)	Oil pipe assy (connecting rod)	1
N 123		ME10E8688	パイプヒモクミ (ウワジクメタル ナカ)	Oil pipe assy (drive shaft bushing C)	1
N 124		MS14A3780	ホルダ	Holder	1
N 125		MF60A5740	フェルト	Felt	1
N 126		MS14A0740	フェルト	Felt	1
N 127		ME10E9688	パイプヒモクミ (シタジクメタル ウシロ)	Oil pipe assy (hook shaft bushing R)	1
N 128		MB60A1780	ホルダ	Holder	1
N 129		ME10F0688	パイプヒモクミ (カンユ)	Oil pipe assy (circulation)	1
N 130		MS01A9796	ホルダ	Holder	1

P 配線検出器関係
CABLE COMPONENT & DETECTOR MECHANISM

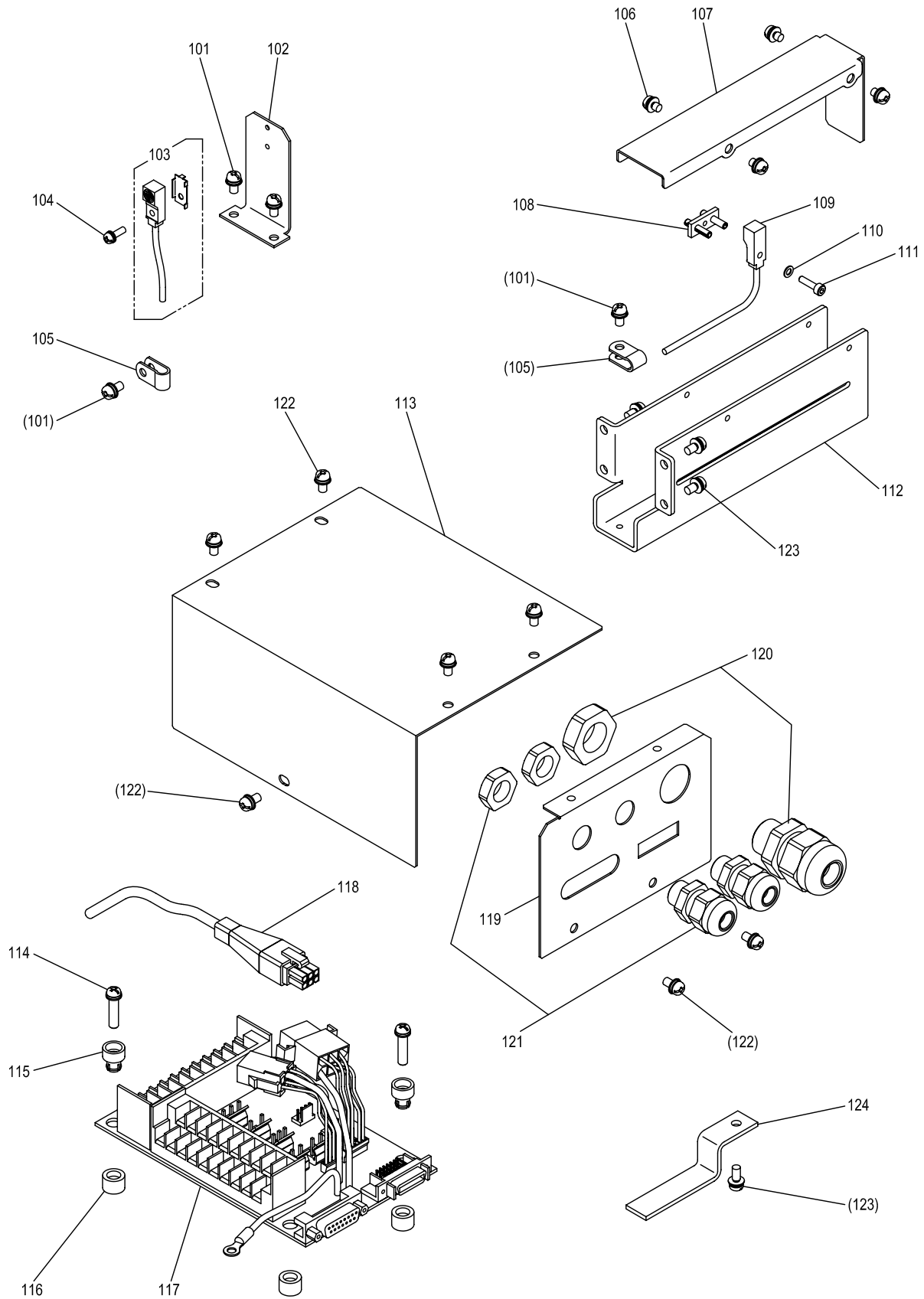

[P]配線・検出器関係

CABLE COMPONENT & DETECTOR MECHANISM

Fig no.	変更 Mod.	部品コード Parts no.	品名	Description	数量 Amt. Req.
P 101		M91054004	SW-PW ⁺ ラマイナ ⁺ ネジ ⁺ M4X8	Screw M4X8	4
P 102		ME10A0408	ケンシュツダイ X	Detector bracket X	1
P 103		ME10E0484	キンセツスイッチ X	Detector X	1
P 104		M90971004	SW-PW ⁺ ラマイナ ⁺ ネジ ⁺ M3X10	Screw M3X10	1
P 105		M94003099	ナイロンクリップ AB-3N	Nylon clip AB-3N	2
P 106		M91058004	SW-PW ⁺ ラマイナ ⁺ ネジ ⁺ M4X6	Screw M4X6	4
P 107		ME10A9339	Yケンシュツキカバー	Detector cover Y	1
P 108		ME10A2780	ネジ ⁺ イタクミタテ	Holder plate assy	1
P 109		ME10E1484	キンセツスイッチ Y	Detector Y	1
P 110		M90317050	ザガ ⁺ ネ 3	Washer 3	1
P 111		M93011021	ロツカクアナツキボルト M3X12	Bolt M3X12	1
P 112		ME10A1408	Yケンシュツダイ	Detector bracket Y	1
P 113		MB60A5339	Pハンカバー	Circuit board cover	1
P 114		M91057004	SW-PW ⁺ ラマイナ ⁺ ネジ ⁺ M4X20	Screw M4X20	4
P 115		MB60A0366	ワシタツチブツシユ	Nylon bush	4
P 116		MB60A2352	ワシタツチブツシユ	Nylon bush	4
P 117		M95003096	Pハンクミタテ	Print circuit board	1
P 118		K14M71725402	ケーブル (エンコーダ)	Cable (Encoder)	1
P 119		MB60A5601	コネクタトリツケイタ	Connector panel	1
P 120		MB60A5780	コード ⁺ ブツシユ ⁺ ダイ	Cord bushing (large)	1
P 121		MB60A6780	コード ⁺ ブツシユ ⁺ シヨウ	Cord bushing (small)	2
P 122	B	M91071004	SW-MW ⁺ ラマイナ ⁺ ネジ ⁺ M4X8	Screw M4X8	7
P 123	B	M91056004	SW-PW ⁺ ラマイナ ⁺ ネジ ⁺ M4X10	Screw M4X10	5
P 124	B	ME10A0780	ホルダ	Holder	1

Q テーブル関係
TABLE & STAND

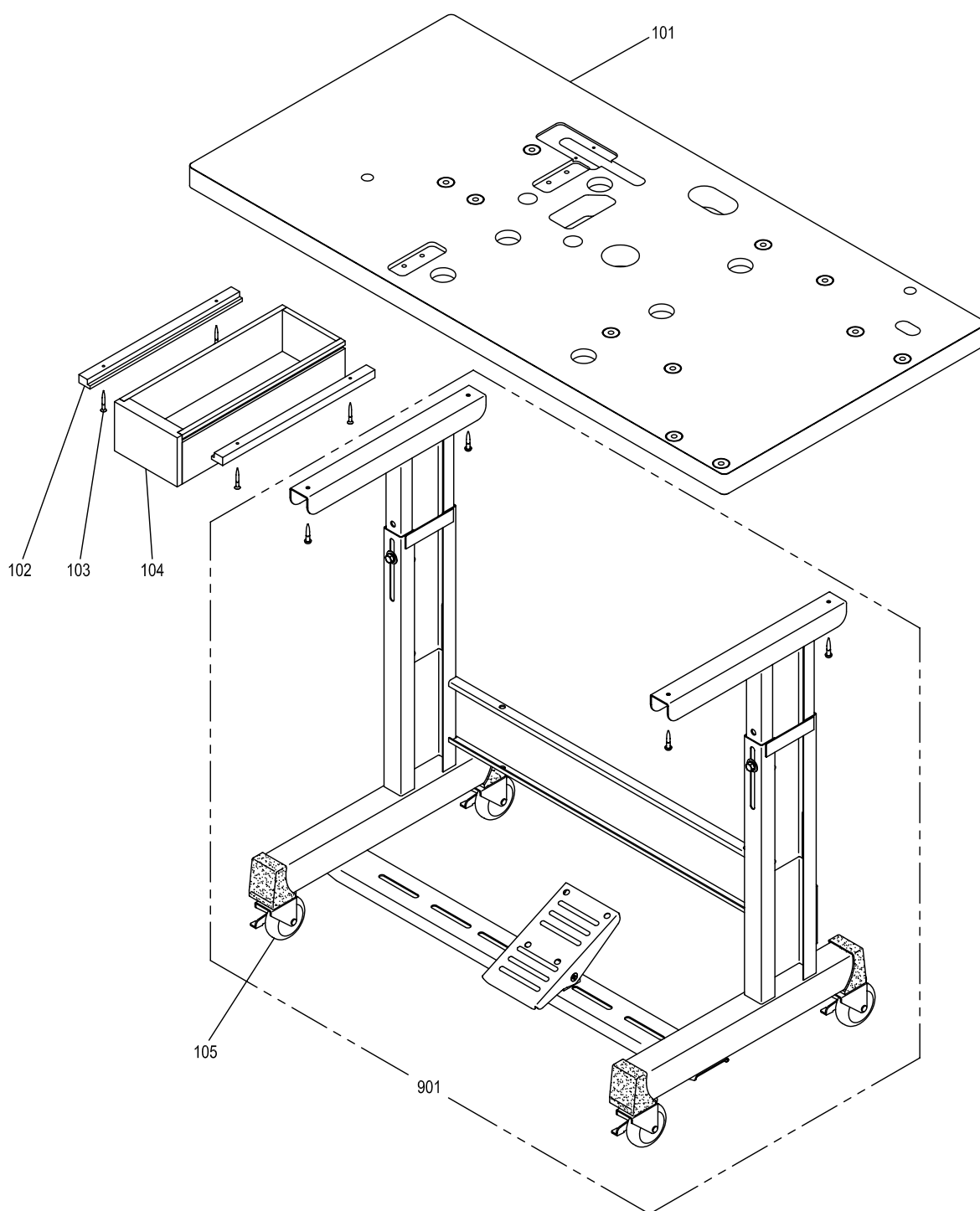

[Q]テーブル関係
TABLE & STAND

Fig no.	変更 Mod.	部品コード Parts no.	品 名	Description	数量 Amt. Req.
Q 101		ME10A0595	テシタ	Table top	1
Q 102		MB60A3957	レール	Rail	2
Q 103		M90406040	Pサヲモクネジ φ4.5X38	Wooden screw φ4.5X38	4
Q 104		MB60A0719	ヒキダシ	Drawer	1
Q 105		MB60A1368	キャスト	Caster	4
Q 901		MB60E0150	キヤククミタテ	Leg assy	1

R 付属品(1)
ACCESSORIES(1)

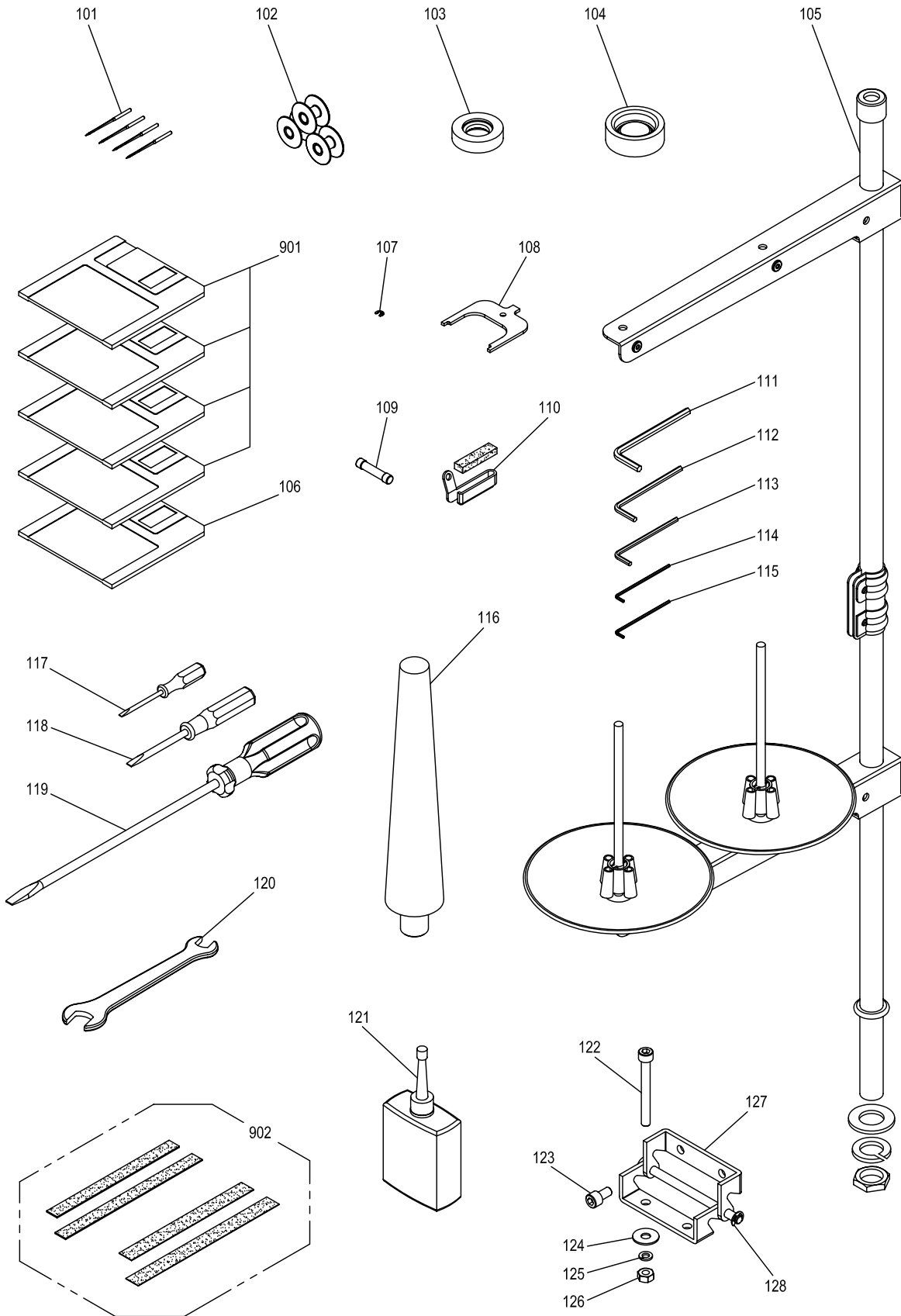

[R] 付属品(1)
ACCESSORIES(1)

Fig no.	変更 Mod.	部品コード Parts no.	品 名	Description	数量 Amt. Req.
R 101		MS02A0128	ミシンハリ DPX17#18	Needle DPX17#18	4
R 102		MA10A0123	ホビン	Bobbin	3
R 103		MS03A0417	ゴムワ (トマキヨウ)	Tire (for bobbin winder)	1
R 104		MB60A0419	ホウシゴム	Rubber cushion	6
R 105		MF40E0193	イトタテダイクミタテ	Cotton stand assy	1
R 106		MB60A1990	データフロッピーディスク	Pattern data F/D	1
R 107		M90513065	Eカ外メワ 2.5	E-type retaining ring 2.5	5
R 108		MF01A0565	カクチョウセイグ	Speed command disk adjusting plate	1
R 109		M82510FUS	ヒューズ	Fuse	2
R 110		MS03A0181	イトアンナイ	Thread guide	1
R 111		MS01A1976	ロッカクホウレンチ 4	Hexagonal wrench 4	1
R 112		MB18A1479	ロッカクホウレンチ 3	Hexagonal wrench 3	1
R 113		MB18A0479	ロッカクホウレンチ 2.5	Hexagonal wrench 2.5	1
R 114		MS10A0976	ロッカクホウレンチ 1.5	Hexagonal wrench 1.5	1
R 115		MN25A0479	ロッカクホウレンチ 1/16"	Hexagonal wrench 1/16"	1
R 116		MA10A1613	トウフササエ	Head rest	1
R 117		MB02A1608	ドライバ (ショウ)	Screw driver (small)	1
R 118		MB02A0608	ドライバ (チュウ)	Screw driver (middle)	1
R 119		MF00A0608	ドライバ (ダイ)	Screw driver (large)	1
R 120		MM10A1479	スパナ10-14	Spanner 10-14	1
R 121		MF10A0149	アブラサシ	Oiler with oil	1
R 122		M96020021	ロッカクアナツキボルト M6X55	Bolt M6X55	4
R 123		M96002017	セフテイソケット M6X12	Bolt M6X12	4
R 124		M90630050	ザガネ 6.5-18	Washer 6.5-18	4
R 125		M90624053	ハネザガネ 6	Spring washer 6	4
R 126		M91576045	ナット M6	Nut M6	4
R 127		MB60A0560	チョウハン	Hinge	2
R 128	B	M90809065	Eカ外メワ 5	E-type retaining ring 5	2
R 901		ME10A0990	システムフロッピーディスク (4マイ)	System F/D (4discs)	1
R 902		ME10E0691	パッキンセット	Clamp pad set	1

S 付属品(2)
ACCESSORIES(2)

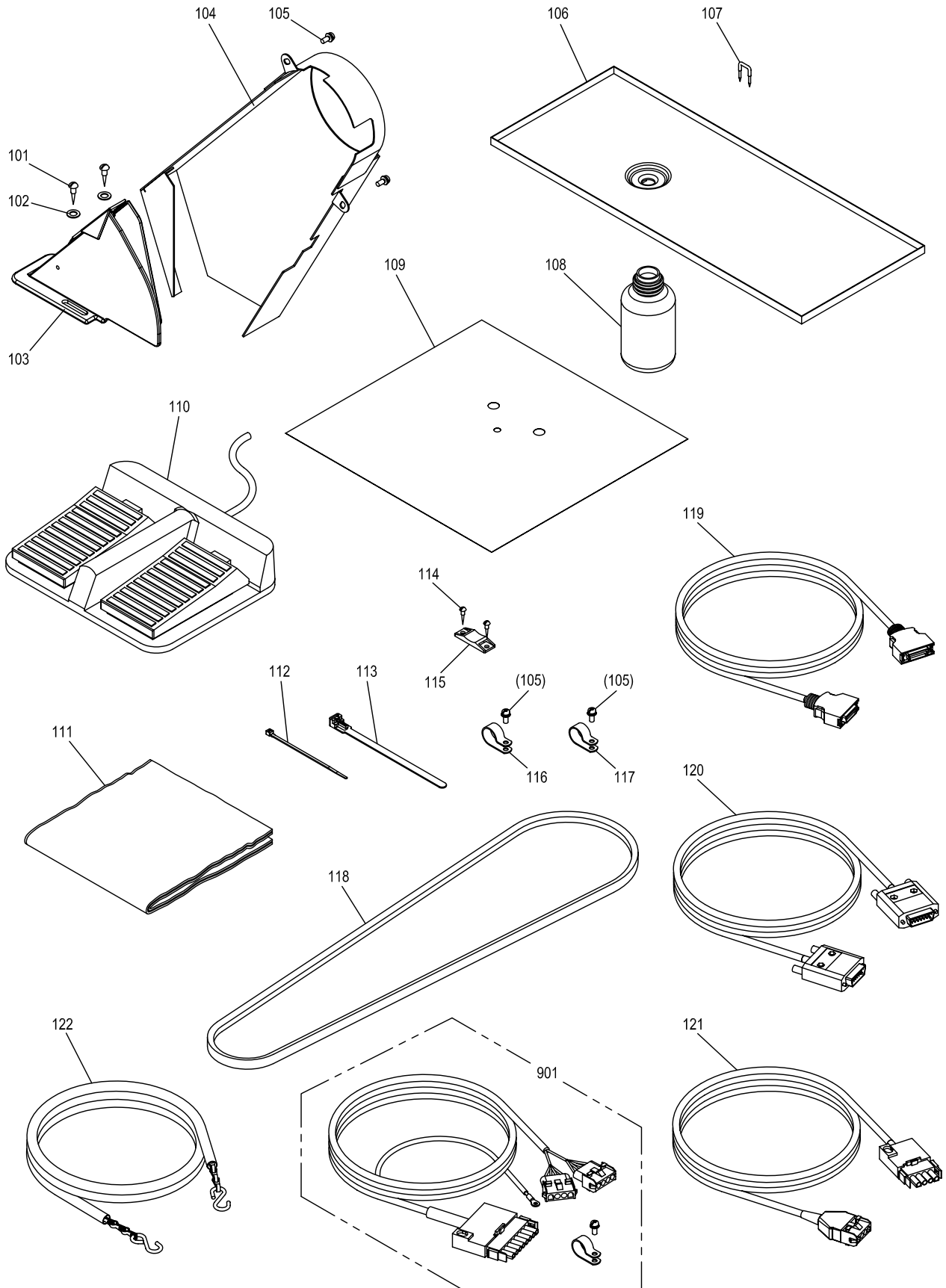

[S]付属品(2)
ACCESSORIES(2)

Fig no.	変更 Mod.	部品コード Parts no.	品名	Description	数量 Amt. Req.
S 101		M90409041	マルモクネジ 4.5X20	Wooden screw 4.5X20	2
S 102		M90632050	ザカネ 6	Washer 6	2
S 103		ME10E1776	ベルトカバー	Belt cover	1
S 104		ME10E0776	ベルトカバー	Belt cover	1
S 105		M91056004	SW-PWプライナヘネジ M4X10	Screw M4X10	4
S 106		MB60E0131	オイルパン	Oil pan	1
S 107		K14M95610701	ステッフル	Staple	4
S 108		MF20A0130	アブラビン	Oil bottle	1
S 109		ME10A0797	ホゴフィルム	Film sheet	1
S 110		M860A0FSW	フットスイッチ	Foot switch	1
S 111		MQ10A0734	ビニルカバー	Polyethylene cover	1
S 112		MG51A0201	ハインダー	Cord tie	1
S 113		MB60A0201	ハインダー	Cord tie	2
S 114		M90306041	マルモクネジ 3.1X16	Wooden screw 3.1X16	4
S 115		MB60A0420	コテイグ	Tie holder	2
S 116		MB60A2620	ナイロンクリップ AB-10N	Nylon clip AB-10N	1
S 117		MB60A1620	ナイロンクリップ AB-8N	Nylon clip AB-8N	1
S 118		MS10A0777	Vベルト M51	V-belt M51	1
S 119		M97319099	ケーブル (ニューリヨクシコウ)	Cable (input signal)	1
S 120		M97320099	ケーブル (ソレノイド)	Cable (solenoid)	1
S 121		M97318099	ケーブル (サーボモータテンゲン)	Cable (servo motor)	1
S 122		MB05A0376	クサリ	Chain	1
S 901		M97355099	ケーブル (パルスモータ)	Cable (pulse motor)	1

T オプションパーツ
OPTION PARTS

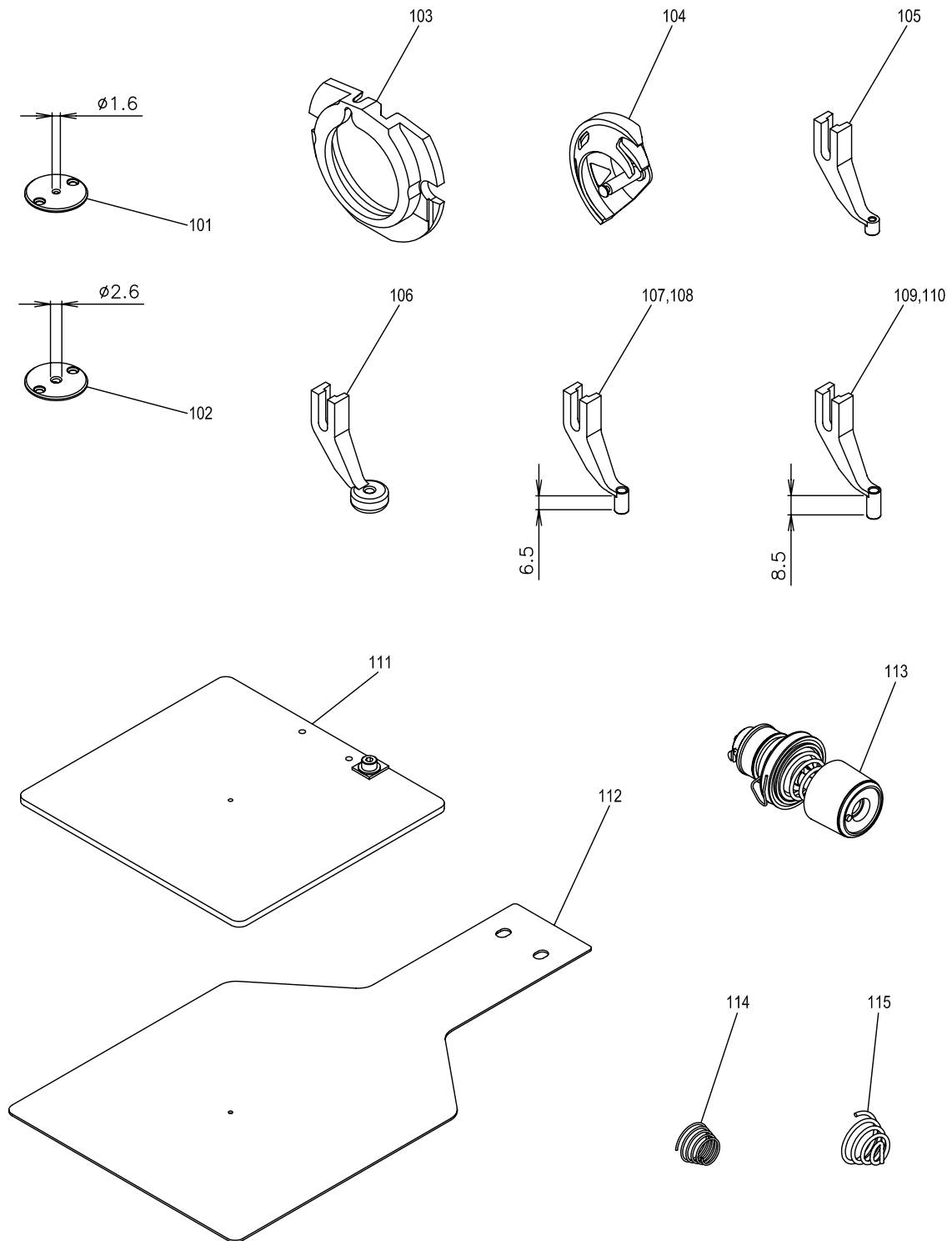

[T]オプションパーツ
OPTION PARTS

Fig no.	変更 Mod.	部品コード Parts no.	品 名	Description	数量 Amt. Req.
T 101		MS03A0101	ハリイタ (ウスモノヨウ) φ 1.6	Needle plate (for light) φ 1.6	1
T 102		MS03A2101	ハリイタ (アツモノヨウ) φ 2.6	Needle plate (for heavy) φ 2.6	1
T 103		MS01A1616	ナカガマオサエ (アツモノヨウ)	Inner hook clamber (for heavy)	1
T 104		MS17A1120	ナカガマ (アツモノヨウ)	Inner hook (for heavy)	1
T 105		MV30A1256	ナカオサエ (ウスモノヨウ)	Presser foot (for light)	1
T 106		MV35A0106	サラオサエ	Presser foot	1
T 107		MS03A0256	ナカオサエ φ 3	Presser foot φ 3	1
T 108		MS03A1256	ナカオサエ φ 2	Presser foot φ 2	1
T 109		MA35A0256	ナカオサエ φ 3	Presser foot φ 3	1
T 110		MA35A1256	ナカオサエ φ 2	Presser foot φ 2	1
T 111		ME10E0272	オサエクミタテ (ソザイ)	Clamp frame complete (blank)	1
T 112		ME10A1272	オクリイタ (ソザイ)	Feed plate (blank)	1
T 113		MS04E1210	ウワイトチヨウセツキ (クミ)	Thread tension regulator assy	1
T 114		MF10A1245	エンスイパネ (プリテンションヨウ)	Spring (for pretension)	1
T 115		MN10A3245	エンスイパネ (ウワイトチヨウセツキヨウ)	Spring (for thread tension regulator)	1

索引
INDEX-1

部品コード Parts No.	ページ Page	Fig No.	部品コード Parts No.	ページ Page	Fig No.	部品コード Parts No.	ページ Page	Fig No.	部品コード Parts No.	ページ Page	Fig No.
K14M71725402	*** P27	*** P 118	M90802002	*** P19	*** K 102	M91057004	*** P27	*** P 114	M91603003	*** P21	*** L 121
K14M95610701	*** P33	*** S 107	M90802003	*** P9	*** E 129	M91057020	*** P5	*** C 121	M91605045	*** P5	*** C 110
K14S92221040	*** P21	*** L 157	↑	*** P23	*** M 111	↑	*** P23	*** M 115	M91606001	*** P7	*** D 133
M82510FUS	*** P31	*** R 109	M90806002	*** P3	*** B 117	M91058004	*** P27	*** P 106	↑	*** P21	*** L 129
M860A0FSW	*** P33	*** S 110	M90809065	*** P31	*** R 128	M91058020	*** P21	*** L 113	M91652020	*** P19	*** K 146
M90001060	*** P9	*** E 128	M90815002	*** P7	*** D 130	M91059004	*** P7	*** D 103	M91688015	*** P21	*** L 109
M90101017	*** P19	*** K 152	M90817060	*** P17	*** J 114	M91060021	*** P13	*** G 114	M91689015	*** P21	*** L 107
M90102017	*** P19	*** K 138	M90818060	*** P17	*** J 124	M91069004	*** P19	*** K 118	M91801035	*** P21	*** L 101
M90105062	*** P15	*** H 145	M90823050	*** P3	*** B 109	M91071004	*** P3	*** B 139	M91802006	*** P7	*** D 132
M90110053	*** P15	*** H 144	M90853002	*** P9	*** E 126	↑	*** P27	*** P 122	M91802045	*** P9	*** E 105
↑	*** P21	*** L 166	M90859004	*** P3	*** B 138	M91083004	*** P13	*** G 131	↑	*** P21	*** L 102
M90204060	*** P5	*** C 101	M90875045	*** P23	*** M 109	M91101046	*** P5	*** C 139	M91910080	*** P3	*** B 107
M90306041	*** P33	*** S 114	M90901002	*** P5	*** C 102	M91102045	*** P19	*** K 164	M92003050	*** P21	*** L 165
M90307053	*** P23	*** M 108	M90901020	*** P17	*** J 103	M91104045	*** P19	*** K 150	M92004050	*** P21	*** L 164
M90316050	*** P13	*** G 121	M90906003	*** P3	*** B 137	M91108001	*** P19	*** K 162	M92057022	*** P3	*** B 112
M90317050	*** P23	*** M 107	↑	*** P19	*** K 127	M91109002	*** P15	*** H 108	M93001050	*** P7	*** D 106
↑	*** P27	*** P 110	M90908003	*** P3	*** B 123	↑	*** P17	*** J 104	M93003021	*** P13	*** G 108
M90325065	*** P21	*** L 128	↑	*** P21	*** L 115	M91109045	*** P19	*** K 158	M93004021	*** P15	*** H 138
M90330065	*** P7	*** D 105	M90920002	*** P5	*** C 141	M91110002	*** P3	*** B 121	M93006050	*** P9	*** E 130
M90406040	*** P29	*** Q 103	M90921002	*** P13	*** G 102	M91112002	*** P19	*** K 106	M93007020	*** P13	*** G 129
M90409041	*** P33	*** S 101	M90922002	*** P21	*** L 139	M91116002	*** P15	*** H 112	M93011021	*** P27	*** P 111
M90421050	*** P7	*** D 102	M90939002	*** P5	*** C 142	↑	*** P21	*** L 160	M93202045	*** P21	*** L 130
↑	*** P17	*** J 137	M90943002	*** P17	*** J 107	M91127015	*** P15	*** H 120	M93202047	*** P21	*** L 131
↑	*** P19	*** K 109	M90971004	*** P27	*** P 104	↑	*** P19	*** K 101	M94001001	*** P11	*** F 107
↑	*** P21	*** L 163	M90990002	*** P3	*** B 142	M91129015	*** P19	*** K 130	M94001021	*** P15	*** H 104
M90422050	*** P17	*** J 132	↑	*** P7	*** D 136	M91131002	*** P21	*** L 143	M94002017	*** P21	*** L 152
M90423060	*** P21	*** L 146	↑	*** P19	*** K 119	M91137015	*** P15	*** H 111	M94003017	*** P13	*** G 103
M90424053	*** P19	*** K 108	↑	*** P21	*** L 151	↑	*** P17	*** J 111	M94003021	*** P13	*** G 125
M90432060	*** P21	*** L 158	M90991002	*** P13	*** G 124	M91139015	*** P17	*** J 101	M94003099	*** P25	*** N 116
M90447037	*** P3	*** B 115	M91001075	*** P11	*** F 101	M91180080	*** P3	*** B 119	↑	*** P27	*** P 105
M90448037	*** P11	*** F 130	M91003022	*** P13	*** G 119	M91203002	*** P9	*** E 101	M94004099	*** P25	*** N 104
M90500085	*** P9	*** E 115	M91003070	*** P11	*** F 128	M91214015	*** P19	*** K 133	M94006017	*** P11	*** F 109
M90504053	*** P11	*** F 123	↑	*** P17	*** J 120	M91219015	*** P21	*** L 142	↑	*** P17	*** J 130
↑	*** P19	*** K 161	M91004045	*** P13	*** G 132	M91221001	*** P7	*** D 122	M94007017	*** P17	*** J 133
M90505065	*** P15	*** H 117	↑	*** P19	*** K 107	↑	*** P9	*** E 132	M94008017	*** P13	*** G 104
M90511050	*** P11	*** F 116	M91004067	*** P5	*** C 129	M91222001	*** P9	*** E 104	M94009021	*** P17	*** J 138
↑	*** P15	*** H 103	M91005067	*** P5	*** C 131	M91223001	*** P7	*** D 137	M94035021	*** P13	*** G 109
↑	*** P17	*** J 116	M91011004	*** P3	*** B 127	M91224001	*** P19	*** K 131	↑	*** P17	*** J 136
↑	*** P19	*** K 160	M91013004	*** P3	*** B 144	M91276004	*** P3	*** B 101	M95001001	*** P11	*** F 104
M90511065	*** P11	*** F 110	↑	*** P5	*** C 123	M91304080	*** P3	*** B 106	M95001017	*** P11	*** F 124
M90513065	*** P19	*** K 136	M91014004	*** P3	*** B 120	M91331004	*** P19	*** K 116	M95001021	*** P9	*** E 123
↑	*** P31	*** R 107	M91050020	*** P17	*** J 118	M91382045	*** P15	*** H 102	↑	*** P15	*** H 129
M90518060	*** P15	*** H 128	M91053020	*** P3	*** B 124	↑	*** P19	*** K 112	M95002017	*** P15	*** H 114
M90543060	*** P15	*** H 121	↑	*** P7	*** D 120	M91400010	*** P3	*** B 134	↑	*** P17	*** J 134
M90601064	*** P5	*** C 133	M91054004	*** P3	*** B 103	↑	*** P17	*** J 131	↑	*** P21	*** L 162
M90605010	*** P19	*** K 122	↑	*** P15	*** H 143	M91503001	*** P9	*** E 111	M95003021	*** P19	*** K 141
M90618060	*** P15	*** H 127	↑	*** P23	*** M 101	M91506001	*** P21	*** L 136	M95003096	*** P27	*** P 117
M90619060	*** P15	*** H 124	↑	*** P25	*** N 105	M91515022	*** P21	*** L 147	M95004017	*** P11	*** F 115
M90620060	*** P15	*** H 130	↑	*** P27	*** P 101	M91520002	*** P7	*** D 112	↑	*** P17	*** J 115
M90624053	*** P31	*** R 125	M91055020	*** P5	*** C 124	M91551015	*** P21	*** L 125	M95004020	*** P3	*** B 128
M90630050	*** P31	*** R 124	M91056004	*** P19	*** K 142	M91572045	*** P21	*** L 122	M95004021	*** P9	*** E 107
M90631050	*** P15	*** H 146	↑	*** P21	*** L 104	M91576045	*** P19	*** K 145	↑	*** P19	*** K 151
↑	*** P21	*** L 123	↑	*** P23	*** M 102	↑	*** P31	*** R 126	M95005017	*** P17	*** J 141
M90632050	*** P21	*** L 133	↑	*** P27	*** P 123	M91602001	*** P7	*** D 118	↑	*** P19	*** K 111
↑	*** P33	*** S 102	↑	*** P33	*** S 105	M91602046	*** P5	*** C 111	M95008021	*** P15	*** H 101

索引
INDEX-2

部品コード Parts No.	ページ Page	Fig No.	部品コード Parts No.	ページ Page	Fig No.	部品コード Parts No.	ページ Page	Fig No.	部品コード Parts No.	ページ Page	Fig No.
M95011021	...	P15	...	H	116	MB60A0420	...	P33	...	S	115
M95018021	...	P15	...	H	134	MB60A0476	...	P11	...	F	113
M95035021	...	P11	...	F	119	MB60A0477	...	P17	...	J	109
M95036021	...	P11	...	F	120	MB60A0523	...	P11	...	F	102
M95048021	...	P11	...	F	122	MB60A0560	...	P31	...	R	127
M95049021	...	P19	...	K	163	MB60A0601	...	P3	...	B	122
M95060095	...	P11	...	F	108	MB60A0694	...	P7	...	D	111
M96001070	...	P15	...	H	132	MB60A0719	...	P29	...	Q	104
M96002017	...	P31	...	R	123	MB60A0740	...	P9	...	E	102
M96002020	...	P9	...	E	114	MB60A0750	...	P3	...	B	110
M96004052	...	P19	...	K	129	MB60A0778	...	P11	...	F	114
M96020021	...	P31	...	R	122	MB60A0780	...	P15	...	H	142
M96033021	...	P15	...	H	139	MB60A0915	...	P23	...	M	105
M97318099	...	P33	...	S	121	MB60A0957	...	P13	...	G	126
M97319099	...	P33	...	S	119	MB60A1368	...	P29	...	Q	105
M97320099	...	P33	...	S	120	MB60A1454	...	P11	...	F	111
M97355099	...	P33	...	S	901	MB60A1601	...	P5	...	C	128
M97356099	...	P23	...	M	103	MB60A1620	...	P33	...	S	117
M98003015	...	P9	...	E	108	MB60A1626	...	P21	...	L	140
M99002052	...	P17	...	J	112	MB60A1758	...	P11	...	F	117
M99006063	...	P5	...	C	126	MB60A1780	...	P25	...	N	128
↑	...	P21	...	L	114	MB60A1957	...	P13	...	G	130
MA04A0477	...	P13	...	G	118	MB60A1990	...	P31	...	R	106
MA04A1530	...	P5	...	C	120	MB60A2352	...	P27	...	P	116
MA04A2530	...	P5	...	C	122	MB60A2406	...	P7	...	D	101
MA10A0120	...	P9	...	E	121	MB60A2601	...	P13	...	G	106
MA10A0123	...	P9	...	E	119	MB60A2620	...	P33	...	S	116
MA10A0123	...	P31	...	R	102	MB60A2682	...	P11	...	F	103
MA10A0454	...	P15	...	H	107	MB60A3682	...	P11	...	F	112
MA10A0455	...	P17	...	J	117	MB60A3957	...	P29	...	Q	102
MA10A0601	...	P19	...	K	115	MB60A5339	...	P27	...	P	113
MA10A0729	...	P15	...	H	106	MB60A5601	...	P27	...	P	119
MA10A0950	...	P15	...	H	105	MB60A5780	...	P27	...	P	120
MA10A1613	...	P31	...	R	116	MB60A6780	...	P27	...	P	121
MA10A1950	...	P15	...	H	109	MB60E0131	...	P33	...	S	106
MA10B2476	...	P19	...	K	125	MB60E0150	...	P29	...	Q	901
MA16E0210	...	P5	...	C	901	MB60E0190	...	P5	...	C	903
MA20A0194	...	P5	...	C	127	MB60E0234	...	P7	...	D	904
MA20A0392	...	P19	...	K	134	MB60E0682	...	P7	...	D	113
MA20A0476	...	P5	...	C	118	MB60E0950	...	P5	...	C	125
MA20A0584	...	P3	...	B	125	MB60E0982	...	P23	...	M	113
MA20A0603	...	P19	...	K	113	MB60E1682	...	P7	...	D	901
MA20A0740	...	P9	...	E	113	MB60E1956	...	P9	...	E	901
MA35A0256	...	P35	...	T	109	MB60E3339	...	P23	...	M	902
MA35A1256	...	P35	...	T	110	MB60E6339	...	P3	...	B	136
MB02A0608	...	P31	...	R	118	MB62A0352	...	P3	...	B	102
MB02A1608	...	P31	...	R	117	MB62A4601	...	P3	...	B	143
MB05A0376	...	P33	...	S	122	ME03A0270	...	P23	...	M	117
MB18A0479	...	P31	...	R	113	ME03A8339	...	P3	...	B	145
MB18A1479	...	P31	...	R	112	ME10A0105	...	P17	...	J	140
MB60A0196	...	P17	...	J	139	ME10A0148	...	P9	...	E	112
MB60A0201	...	P33	...	S	113	ME10A0230	...	P7	...	D	121
MB60A0366	...	P27	...	P	115	ME10A0257	...	P15	...	H	136
MB60A0407	...	P13	...	G	111	ME10A0261	...	P21	...	L	103
MB60A0419	...	P31	...	R	104	ME10A0266	...	P17	...	J	108
ME10A0267	...	P15	...	H	133	ME10A0272	...	P17	...	J	142
ME10A0307	...	P17	...	J	128	ME10A0308	...	P17	...	J	127
ME10A0339	...	P3	...	B	132	ME10A0352	...	P15	...	H	122
ME10A0390	...	P11	...	F	121	ME10A0408	...	P27	...	P	102
ME10A0426	...	P13	...	G	112	ME10A0429	...	P17	...	J	105
ME10A0454	...	P15	...	H	131	ME10A0457	...	P17	...	J	122
ME10A0523	...	P11	...	F	127	ME10A0477	...	P13	...	G	110
ME10A0571	...	P11	...	F	106	ME10A0572	...	P21	...	L	105
ME10A0595	...	P29	...	Q	101	ME10A0595	...	P29	...	Q	101
ME10A0601	...	P17	...	J	135	ME10A0700	...	P17	...	J	110
ME10A0700	...	P17	...	J	110	ME10A0729	...	P17	...	J	126
ME10A0729	...	P17	...	J	126	ME10A0738	...	P21	...	L	148
ME10A0738	...	P21	...	L	148	ME10A0742	...	P3	...	B	105
ME10A0742	...	P3	...	B	105	ME10A0743	...	P15	...	H	118
ME10A0743	...	P15	...	H	118	ME10A0758	...	P11	...	F	126
ME10A0758	...	P11	...	F	126	ME10A0763	...	P21	...	L	111
ME10A0763	...	P21	...	L	111	ME10A0778	...	P11	...	F	131
ME10A0778	...	P11	...	F	131	ME10A0780	...	P27	...	P	124
ME10A0780	...	P27	...	P	124	ME10A0797	...	P3	...	B	141
ME10A0797	...	P3	...	B	141	↑	...	P33	...	S	109
↑	...	P33	...	S	109	ME10A0802	...	P15	...	H	137
ME10A0802	...	P15	...	H	137	ME10A0833	...	P21	...	L	149
ME10A0833	...	P21	...	L	149	ME10A0850	...	P11	...	F	125
ME10A0850	...	P11	...	F	125	ME10A0910	...	P17	...	J	102
ME10A0910	...	P17	...	J	102	ME10A0950	...	P21	...	L	150
ME10A0950	...	P21	...	L	150	ME10A0956	...	P21	...	L	124
ME10A0956	...	P21	...	L	124	ME10A0957	...	P13	...	G	115
ME10A0957	...	P13	...	G	115	ME10A0972	...	P13	...	G	116
ME10A0972	...	P13	...	G	116	ME10A0990	...	P31	...	R	901
ME10A0990	...	P31	...	R	901	ME10A1252	...	P21	...	L	144
ME10A1252	...	P21	...	L	144	ME10A1266	...	P17	...	J	113
ME10A1266	...	P17	...	J	113	ME10A1272	...	P35	...	T	112
ME10A1272	...	P35	...	T	112	ME10A1339	...	P3	...	B	133
ME10A1339	...	P3	...	B	133	ME10A1390	...	P11	...	F	105
ME10A1390	...	P11	...	F	105	ME10A1408	...	P27	...	P	112
ME10A1408	...	P27	...	P	112	ME10A1426	...	P13	...	G	105
ME10A1426	...	P13	...	G	105	ME10A1454	...	P17	...	J	125
ME10A1454	...	P17	...	J	125	ME10A1470	...	P3	...	B	140
ME10A1470	...	P3	...	B	140	ME10A1572	...	P15	...	H	141
ME10A1572	...	P15	...	H	141	ME10A1601	...	P17	...	J	123
ME10A1601	...	P17	...	J	123	ME10A1729	...	P21	...	L	155
ME10A1729	...	P21	...	L	155	ME10A1758	...	P15	...	H	113
ME10A1758	...	P15	...	H	113	ME10A1780	...	P25	...	N	101
ME10A1780	...	P25	...	N	101	ME10A1810	...	P21	...	L	153
ME10A1810	...	P21	...	L	153	ME10A1910	...	P15	...	H	110
ME10A1910	...	P15	...	H	110	ME10A1956	...	P21	...	L	118
ME10A1956	...	P21	...	L	118	ME10A2252	...	P21	...	L	154
ME10A2252	...	P21	...	L	154	ME10A2339	...	P13	...	G	101
ME10A2339	...	P13	...	G	101	ME10A2390	...	P11	...	F	129
ME10A2390	...	P11	...	F	129	ME10A2454	...	P21	...	L	156
ME10A2454	...	P21	...	L	156	ME10A2601	...	P21	...	L	161
ME10A2601	...	P21	...	L	161	ME10A2780	...	P27	...	P	108
ME10A2780	...	P27	...	P	108	ME10A2910	...	P15	...	H	123
ME10A2910	...	P15	...	H	123	ME10A3339	...	P13	...	G	113
ME10A3339	...	P13	...	G	113	ME10A3910	...	P15	...	H	119
ME10A3910	...	P15	...	H	119	ME10A4339	...	P13	...	G	107
ME10A4339	...	P13	...	G	107	ME10A4910	...	P15	...	H	125
ME10A4910	...	P15	...	H	125	ME10A5339	...	P13	...	G	120
ME10A5339	...	P13	...	G	120	ME10A5910	...	P15	...	H	126
ME10A5910	...	P15	...	H	126	ME10A6339	...	P17	...	J	129
ME10A6339	...	P17	...	J	129	ME10A6910	...	P21	...	L	110
ME10A6910	...	P21	...	L	110	ME10A7910	...	P21	...	L	112
ME10A7910	...	P21	...	L	112	ME10A8339	...	P15	...	H	140
ME10A8339	...	P15	...	H	140	ME10A9339	...	P27	...	P	107
ME10A9339	...	P27	...	P	107	ME10E0270	...	P23	...	M	901
ME10E0270	...	P23	...	M	901	ME10E0272	...	P35	...	T	111
ME10E0272	...	P35	...	T	111	ME10E0450	...	P9	...	E	117
ME10E0450	...	P9	...	E	117	ME10E0452	...	P9	...	E	902
ME10E0452	...	P9	...	E	902	ME10E0484	...	P27	...	P	103
ME10E0484	...	P27	...	P	103	ME10E0519	...	P15	...	H	115
ME10E0519	...	P15	...	H	115	ME10E0600	...	P5	...	C	117
ME10E0600	...	P5	...	C	117	ME10E0691	...	P31	...	R	902
ME10E0691	...	P31	...	R	902	ME10E0746	...	P19	...	K	117
ME10E0746	...	P19	...	K	117	ME10E0776	...	P33	...	S	104
ME10E0776	...	P33	...	S	104	ME10E0849	...	P3	...	B	108
ME10E0849	...	P3	...	B	108	ME10E0975	...	P19	...	K	139
ME10E0975	...	P19	...	K	139	ME10E1484	...	P27	...	P	109
ME10E1484	...	P27	...	P	109	ME10E1519	...	P21	...	L	159
ME10E1519	...	P21	...	L	159	ME10E1688	...	P25	...	N	110
ME10E1688	...	P25	...</								

索引
INDEX-3

部品コード Parts No.	ページ Page	Fig No.	部品コード Parts No.	ページ Page	Fig No.	部品コード Parts No.	ページ Page	Fig No.	部品コード Parts No.	ページ Page	Fig No.
MF00E0550	...	P5	...	C	904	MN60A0750	...	P19	...	K	110
MF01A0181	...	P7	...	D	131	MN70A1780	...	P21	...	L	116
MF01A0259	...	P7	...	D	107	MN72A1694	...	P7	...	D	109
MF01A0476	...	P7	...	D	110	MQ10A0734	...	P33	...	S	111
MF01A0565	...	P31	...	R	108	MS01A0121	...	P9	...	E	125
MF01A1476	...	P7	...	D	108	MS01A0160	...	P3	...	B	113
MF10A0149	...	P31	...	R	121	MS01A0192	...	P19	...	K	135
MF10A0181	...	P3	...	B	130	MS01A0329	...	P9	...	E	127
MF10A0187	...	P5	...	C	105	MS01A0348	...	P19	...	K	147
MF10A0267	...	P21	...	L	137	MS01A0350	...	P7	...	D	124
MF10A0325	...	P7	...	D	135	MS01A0361	...	P3	...	B	135
MF10A0553	...	P5	...	C	104	MS01A0383	...	P7	...	D	905
MF10A0555	...	P5	...	C	106	MS01A0477	...	P3	...	B	114
MF10A0709	...	P5	...	C	103	MS01A0508	...	P9	...	E	106
MF10A1245	...	P35	...	T	114	MS01A0572	...	P9	...	E	131
MF10A1555	...	P5	...	C	137	MS01A0611	...	P9	...	E	122
MF10A2740	...	P25	...	N	102	MS01A0660	...	P7	...	D	126
MF20A0130	...	P33	...	S	108	MS01A0663	...	P7	...	D	125
MF21D0181	...	P7	...	D	128	MS01A0740	...	P25	...	N	115
MF36A0245	...	P5	...	C	138	MS01A0761	...	P9	...	E	116
MF36A0750	...	P19	...	K	103	MS01A0833	...	P9	...	E	103
MF36A1180	...	P3	...	B	131	MS01A0891	...	P9	...	E	109
MF40E0193	...	P31	...	R	105	MS01A1392	...	P19	...	K	159
MF60A0700	...	P21	...	L	126	MS01A1476	...	P19	...	K	124
MF60A0742	...	P25	...	N	103	MS01A1572	...	P19	...	K	148
MF60A2740	...	P7	...	D	123	MS01A1616	...	P35	...	T	103
MF60A5740	...	P25	...	N	125	MS01A1739	...	P3	...	B	118
MF70A0350	...	P21	...	L	145	MS01A1740	...	P25	...	N	112
MF70A0352	...	P7	...	D	117	MS01A1976	...	P31	...	R	111
MF70A1180	...	P3	...	B	129	MS01A2392	...	P19	...	K	157
MF80A0780	...	P25	...	N	114	MS01A2572	...	P19	...	K	155
MF90A0361	...	P19	...	K	104	MS01A3352	...	P19	...	K	901
MG30A0664	...	P7	...	D	127	MS01A5454	...	P19	...	K	132
MG30A0740	...	P21	...	L	117	MS01A8796	...	P25	...	N	109
MG30A0760	...	P21	...	L	901	MS01A9796	...	P25	...	N	130
MG30A0833	...	P21	...	L	120	MS01E0351	...	P19	...	K	149
MG30B0226	...	P21	...	L	108	MS01E0430	...	P19	...	K	140
MG30B0740	...	P21	...	L	127	MS01E0580	...	P7	...	D	902
MG43A0181	...	P3	...	B	126	MS01E0975	...	P19	...	K	153
MG50A0740	...	P7	...	D	114	MS02A0128	...	P7	...	D	129
MG51A0201	...	P33	...	S	112	↑	...	P31	...	R	101
MG75A0265	...	P21	...	L	135	MS02A0463	...	P21	...	L	902
MG75A1476	...	P5	...	C	116	MS02A3477	...	P13	...	G	123
MM10A1479	...	P31	...	R	120	MS02A4477	...	P13	...	G	127
MM11A0245	...	P5	...	C	113	MS02E0460	...	P21	...	L	119
MM11A0352	...	P9	...	E	110	MS02E0983	...	P23	...	M	110
MM11A0556	...	P5	...	C	107	MS03A0101	...	P35	...	T	101
MM11A0702	...	P5	...	C	112	MS03A0181	...	P31	...	R	110
MN10A0135	...	P25	...	N	107	MS03A0256	...	P35	...	T	107
MN10A1456	...	P7	...	D	104	MS03A0262	...	P21	...	L	138
MN10A3245	...	P35	...	T	115	MS03A0417	...	P5	...	C	134
MN25A0479	...	P31	...	R	115	↑	...	P31	...	R	103
MN52A1245	...	P5	...	C	108	MS03A0703	...	P21	...	L	132
MN60A0620	...	P3	...	B	104	MS03A1101	...	P19	...	K	123
↑	...	P25	...	N	117	MS03A1256	...	P35	...	T	108
MS03A1530	...	P23	...	M	114						
MS03A1572	...	P21	...	L	134						
MS03A1910	...	P19	...	K	137						
MS03A2101	...	P35	...	T	102						
MS03A2780	...	P25	...	N	113						
MS03A3980	...	P23	...	M	116						
MS03A6154	...	P21	...	L	106						
MS03B0838	...	P19	...	K	128						
MS03E0662	...	P7	...	D	134						
MS03E0981	...	P23	...	M	112						
MS04E1210	...	P35	...	T	113						
MS07A0228	...	P19	...	K	105						
MS08A0454	...	P19	...	K	156						
MS08A0616	...	P9	...	E	120						
MS08A0692	...	P17	...	J	121						
MS08A0708	...	P19	...	K	154						
MS09A0950	...	P9	...	E	124						
MS10A0232	...	P7	...	D	903						
MS10A0688	...	P25	...	N	108						
MS10A0777	...	P33	...	S	118						
MS10A0976	...	P31	...	R	114						
MS10A1456	...	P3	...	B	111						
MS10A1740	...	P7	...	D	115						
MS14A0180	...	P5	...	C	115						
MS14A0350	...	P5	...	C	130						
MS14A0416	...	P15	...	H	135						
MS14A0472	...	P19	...	K	120						
MS14A0553	...	P5	...	C	114						
MS14A0572	...	P5	...	C	132						
MS14A0682	...	P7	...	D	119						
MS14A0740	...	P25	...	N	126						
MS14A0781	...	P11	...	F	132						
MS14A0838	...	P19	...	K	126						
MS14A0972	...	P13	...	G	128						
MS14A3601	...	P19	...	K	143						
MS14A3780	...	P25	...	N	124						
MS14A4454	...	P17	...	J	119						
MS14A4957	...	P13	...	G	117						
MS14E0180	...	P5	...	C	902						
MS17A0125	...	P9	...	E	118						
MS17A1120	...	P35	...	T	104						
MT60A0802	...	P5	...	C	109						
MV30A0256	...	P21	...	L	141						
MV30A1256	...	P35	...	T	105						
MV35A0106	...	P35	...	T	106						
MV88A0740	...	P7	...	D	116						

 **三菱電機株式会社** 〒100-8310 東京都千代田区丸の内 2-2-3(三菱電機ビル)

お問い合わせは下記へどうぞ

F A システム事業本部 機器計画部 駆動機器グループ 〒104-6212 東京都中央区晴海 1-8-12 オフィスタワーZ14 階
代表電話番号 (03) 6221-6160 代表 F A X 番号 (03) 6221-6168

 **MITSUBISHI ELECTRIC CORPORATION**

FACTORY AUTOMATION SYSTEM

OFFICE TOWER "Z" 14F 8-12 1chome, Harumi CHUO-KU, TOKYO 104-6212, JAPAN

Phone : +81-3-6221-6060

Fax : +81-3-6221-6076